

SYWK 40 YTH

Material

Composite for food and beverage

Dimensions

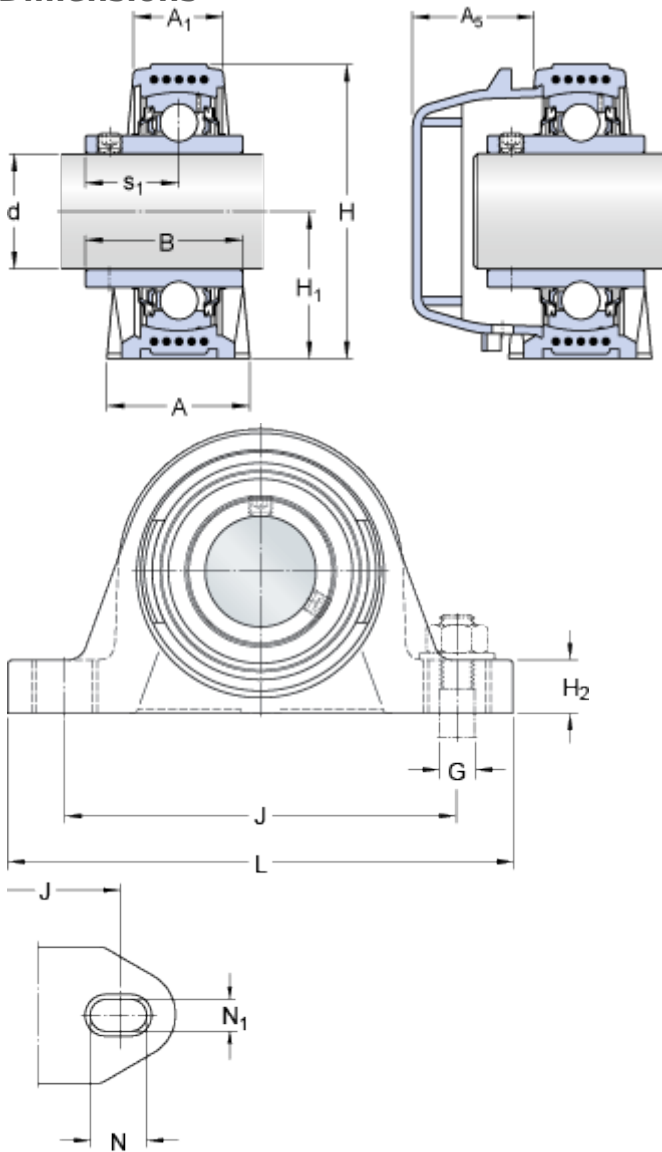

d	40	mm	
A	48	mm	
A ₁	30	mm	
A ₅	33.5	mm	
B	49.2	mm	
H	99	mm	
H ₁	49.2	mm	
H ₂	19	mm	
J	136	mm	
J	max.	143	mm
J	min.	129	mm
L	176	mm	
N	21.5	mm	
N ₁	14.5	mm	
s ₁	30.2	mm	

Calculation data

Basic dynamic load rating	C	26	kN
Basic static load rating	C	19	kN
Fatigue load limit	P _u	0.8	kN
Limiting speed		2800	r/min
(with shaft tolerance h6)			

Mass

Mass bearing unit	0.91	kg
-------------------	------	----

Mounting information

Hexagonal key size for grub screw	N	4	mm
Recommended tightening torque for grub screw		6.5	N·m
Recommended diameter for attachment bolts, mm	G	12	mm

Recommended diameter for attachment bolts, inch

G 0.5 in

Included products

Housing

[SYWK 508 Y](#)

Bearing

[YAR 208-2RF/HV](#)

Assosiated products

End cover

[ECW 208](#)