

# SYJ 80 TF

Material

Cast iron

## Dimensions

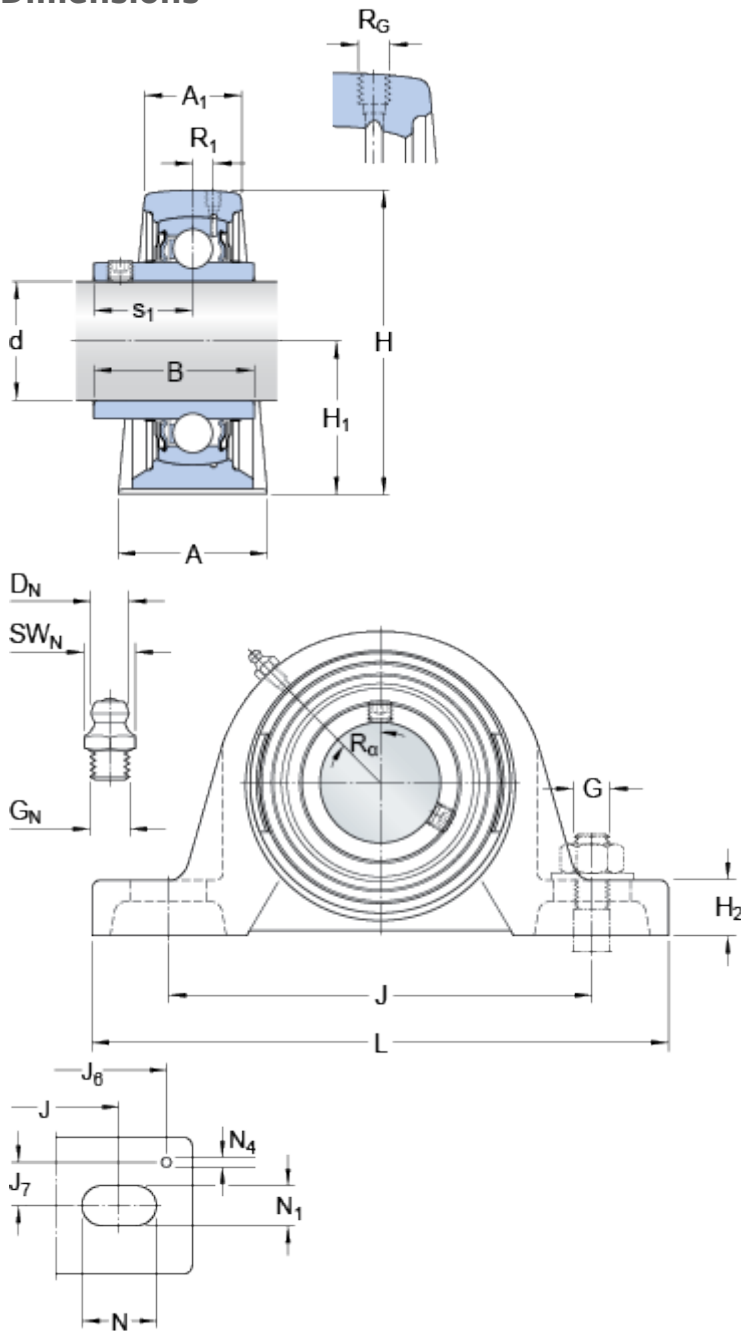

$d$	80	mm
$A$	78	mm
$A_1$	50	mm
$B$	77.8	mm
$H$	175.5	mm
$H_1$	88.9	mm
$H_2$	30	mm
$J$	232	mm
$J$	max. 242	mm
$J$	min. 222	mm
$L$	292	mm
$N$	35	mm
$N_1$	25	mm
$s_1$	47.6	mm

### Threaded hole

$R_G$	1/4-28 UNF
$R_1$	6.5 mm
$R_\alpha$	45 °

### Grease fitting

$D_N$	6.5 mm
$SW_N$	7 mm
$G_N$	1/4-28 SAE-LT

### Dowel pins

$J_6$	270 mm
$J_7$	28 mm
$N_4$	4 mm

## Calculation data

Basic dynamic load rating	C	72.8	kN
Basic static load rating	C	53	kN
Fatigue load limit	$P_u$	2.16	kN
Limiting speed		2400	r/min
(with shaft tolerance h6)			

## Mass

---

Mass bearing unit	8.5	kg
-------------------	-----	----

## Mounting information

---

Hexagonal key size for grub screw	N	5	mm
Recommended tightening torque for grub screw		16.5	N·m
Recommended diameter for attachment bolts, mm	G	20	mm
Recommended diameter for attachment bolts, inch	G	0.75	in

## Included products

---

Housing	<a href="#">SYJ 516</a>
Bearing	<a href="#">YAR 216-2F</a>