

# SYJ 520

## Dimensions

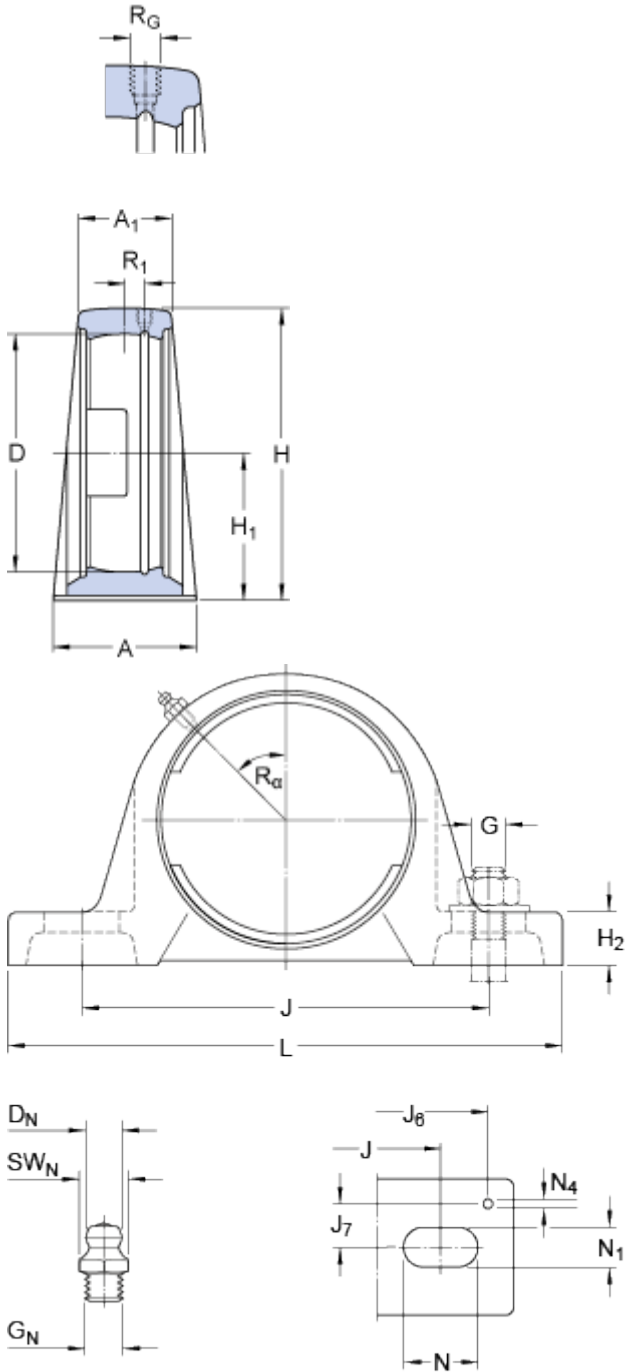

|        |       |    |
|--------|-------|----|
| D      | 180   | mm |
| $H_1$  | 115   | mm |
| A      | 95    | mm |
| $A_1$  | 57    | mm |
| H      | 225.5 | mm |
| $H_2$  | 38    | mm |
| J      | 308   | mm |
| J max. | 330   | mm |
| J min. | 286   | mm |
| L      | 380   | mm |
| N      | 48    | mm |
| $N_1$  | 26    | mm |

### Threaded hole

|            |            |
|------------|------------|
| $R_G$      | 1/4-28 UNF |
| $R_1$      | 10.5 mm    |
| $R_\alpha$ | 45 °       |

### Grease fitting

|        |               |
|--------|---------------|
| $D_N$  | 6.5 mm        |
| $SW_N$ | 7 mm          |
| $G_N$  | 1/4-28 SAE-LT |

### Dowel pins

|       |         |
|-------|---------|
| $J_6$ | 352 mm  |
| $J_7$ | 33.5 mm |
| $N_4$ | 4 mm    |

## Mass

|              |      |    |
|--------------|------|----|
| Mass housing | 12.3 | kg |
|--------------|------|----|

## Mounting information

|   |   |        |    |
|---|---|--------|----|
| Recommended diameter for attachment bolts, mm   | G | 24     | mm |
| Recommended diameter for attachment bolts, inch | G | 0.9375 | in |

