

N 205 ECP

SKF Explorer

Dimensions

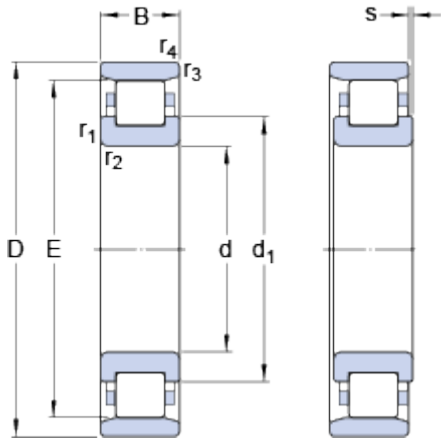

d		25	mm
D		52	mm
B		15	mm
d ₁	≈	34.7	mm
E		46.5	mm
r _{1,2}	min.	1	mm
r _{3,4}	min.	0.6	mm
s	max.	1.3	mm

Abutment dimensions

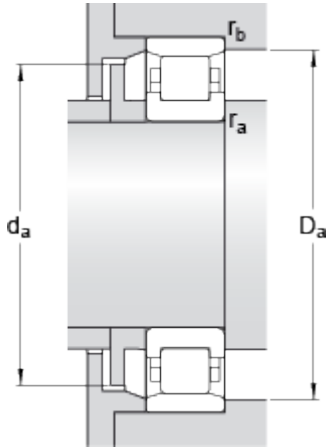

d _a	min.	29.9	mm
d _a	max.	45	mm
D _a	min.	48	mm
D _a	max.	48.5	mm
r _a	max.	1	mm
r _b	max.	0.6	mm

Calculation data

Basic dynamic load rating	C	32.5	kN
Basic static load rating	C	27	kN
Fatigue load limit	P _u	3.35	kN
Reference speed		15000	r/min
Limiting speed		16000	r/min
Calculation factor	k _r	0.12	
Limiting value	e	0.2	
Axial load factor	Y	0.6	

Mass

Mass bearing		0.13	kg
--------------	--	------	----