

# FY 60 TF

Housing material

Cast iron

## Dimensions

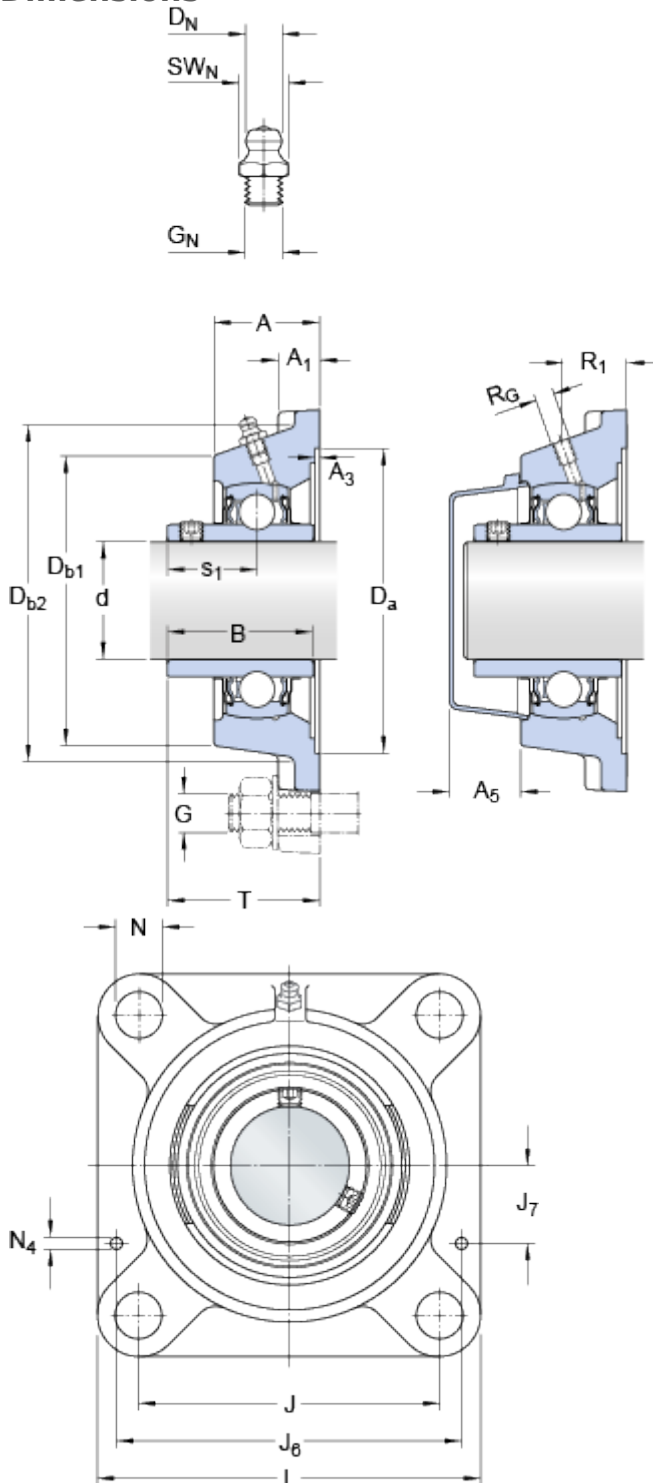

d	60	mm	
D <sub>a</sub>	H11	161.9	mm
D <sub>b1</sub>	130	mm	
D <sub>b2</sub>	143	mm	
A	52	mm	
A <sub>1</sub>	17	mm	
A <sub>3</sub>	H14	3.2	mm
A <sub>5</sub>	35.5	mm	
B	65.1	mm	
J	143	mm	
L	175	mm	
N	18	mm	
s <sub>1</sub>	39.7	mm	
T	73.7	mm	

### Threaded hole

R<sub>G</sub> 1/4-28 UNF

R<sub>1</sub> 34.5 mm

### Grease fitting

D<sub>N</sub> 6.5 mm

SW<sub>N</sub> 7 mm

G<sub>N</sub> 1/4-28 SAE-LT

### Dowel pins

J<sub>6</sub> 161 mm

J<sub>7</sub> 49.5 mm

N<sub>4</sub> 4 mm

## Calculation data

Basic dynamic load rating

C 52.7 kN

Basic static load rating

C 36 kN

Fatigue load limit

P<sub>u</sub> 1.53 kN

Limiting speed

3400 r/min

(with shaft tolerance h6)

## Mass

---

Mass bearing unit	3.85	kg
-------------------	------	----

## Mounting information

---

Thread grub screw	G <sub>2</sub>	M10x1
Hexagonal key size for grub screw	N	5 mm
Recommended tightening torque for grub screw		16.5 N·m
Recommended diameter for attachment bolts, mm	G	16 mm
Recommended diameter for attachment bolts, inch	G	0.625 in

## Included products

---

Housing	<a href="#">FY 512 M</a>
Bearing	<a href="#">YAR 212-2F</a>

## Associated products

---

End cover	<a href="#">ECY 212</a>
-----------	-------------------------