

# FYTWK 50 LTA

Housing material

Composite for food and beverage

## Dimensions

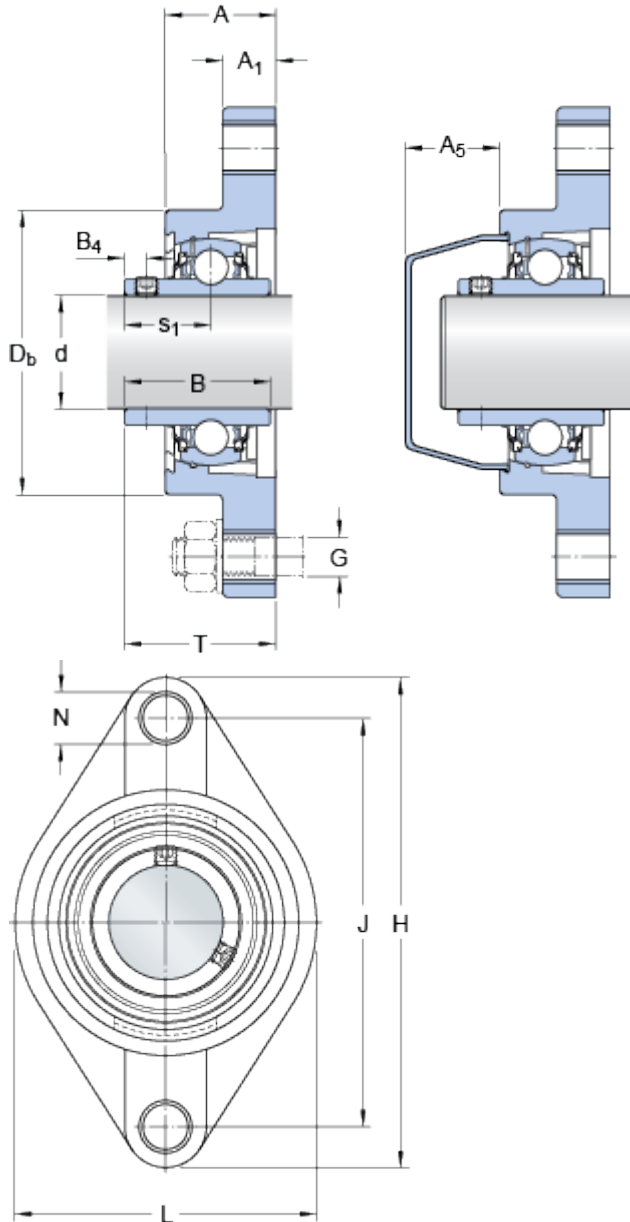

|       |      |    |
|-------|------|----|
| d     | 50   | mm |
| $D_b$ | 115  | mm |
| A     | 43   | mm |
| $A_1$ | 21   | mm |
| $A_5$ | 42.3 | mm |
| B     | 51.6 | mm |
| $B_4$ | 9    | mm |
| J     | 157  | mm |
| H     | 197  | mm |
| L     | 115  | mm |
| N     | 17   | mm |
| $s_1$ | 32.6 | mm |
| T     | 57.6 | mm |

## Calculation data

|                           |       |      |       |
|---------------------------|-------|------|-------|
| Basic dynamic load rating | C     | 35.1 | kN    |
| Basic static load rating  | C     | 23.2 | kN    |
| Fatigue load limit        | $P_u$ | 0.98 | kN    |
| Limiting speed            |       | 2200 | r/min |
| (with shaft tolerance h6) |       |      |       |

## Mass

|                   |      |    |
|-------------------|------|----|
| Mass bearing unit | 1.15 | kg |
|-------------------|------|----|

## Mounting information

|                                   |       |       |
|-----------------------------------|-------|-------|
| Thread grub screw                 | $G_2$ | M10x1 |
| Hexagonal key size for grub screw | N     | 5 mm  |

|   |   |       |     |
|---|---|-------|-----|
| Recommended tightening torque for grub screw    |   | 16.5  | N·m |
| Recommended diameter for attachment bolts, mm   | G | 16    | mm  |
| Recommended diameter for attachment bolts, inch | G | 0.625 | in  |

### Included products

---

|         |                                   |
|---------|-----------------------------------|
| Housing | <a href="#">FYTWK 510 L</a>       |
| Bearing | <a href="#">YAR 210-2RF/VE495</a> |

### Assosiated products

---

|           |                         |
|-----------|-------------------------|
| End cover | <a href="#">ECL 210</a> |
|-----------|-------------------------|