

FYTJ 30 TF

Housing material

Cast iron

Dimensions

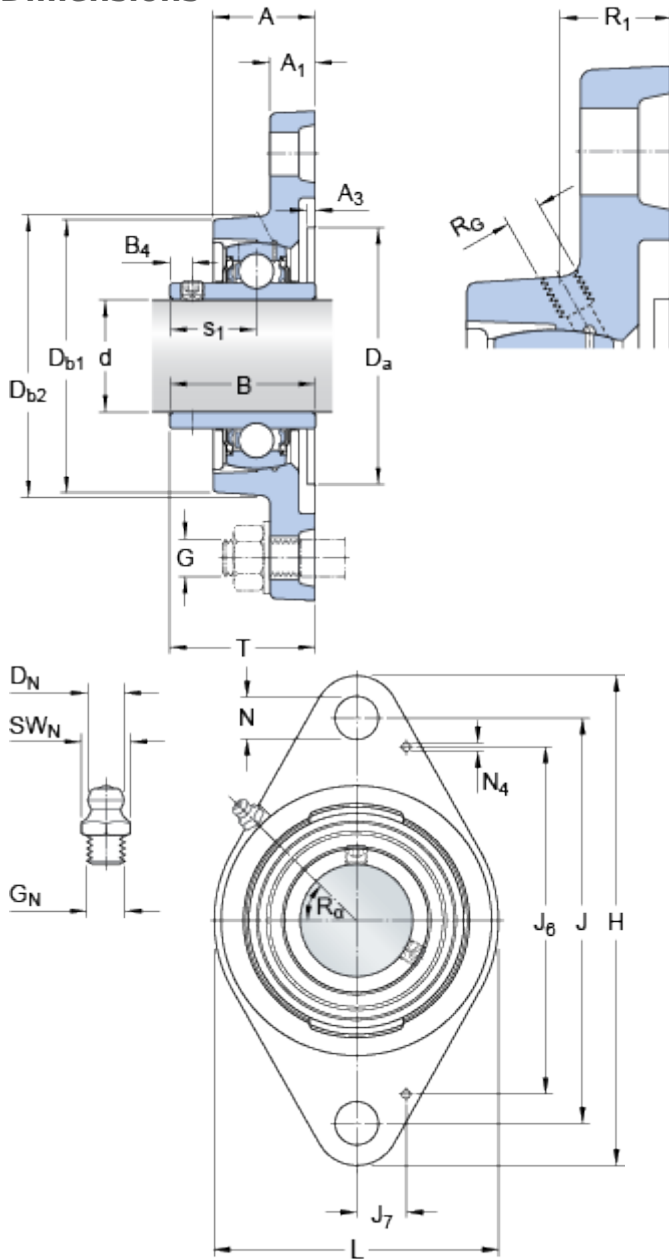

d	30	mm
D _a	H11 76.2	mm
D _{b1}	77	mm
D _{b2}	80	mm
A	30.5	mm
A ₁	13.5	mm
A ₃	H14 3.2	mm
B	38.1	mm
B ₄	5	mm
J	117	mm
H	148	mm
L	80	mm
N	16	mm
s ₁	22.2	mm
T	40.2	mm

Threaded hole

R _G	1/4-28 UNF
R ₁	19 mm
R _α	45 °

Grease fitting

D _N	6.5	mm
SW _N	7	mm
G _N	1/4-28 SAE-LT	

Dowel pins

J ₆	99	mm
J ₇	12.5	mm
N ₄	2	mm

Calculation data

Basic dynamic load rating	C	19.5	kN
Basic static load rating	C	11.2	kN
Fatigue load limit	P _u	0.475	kN
Limiting speed		6300	r/min

(with shaft tolerance h6)

Mass

Mass bearing unit	0.85	kg
-------------------	------	----

Mounting information

Thread grub screw	G ₂	M6x0.75	
Hexagonal key size for grub screw	N	3	mm
Recommended tightening torque for grub screw		4	N·m
Recommended diameter for attachment bolts, mm	G	14	mm
Recommended diameter for attachment bolts, inch	G	0.5625	in

Included products

Housing	FYTJ 506
Bearing	YAR 206-2F