

# FYTB 510 M

## Dimensions

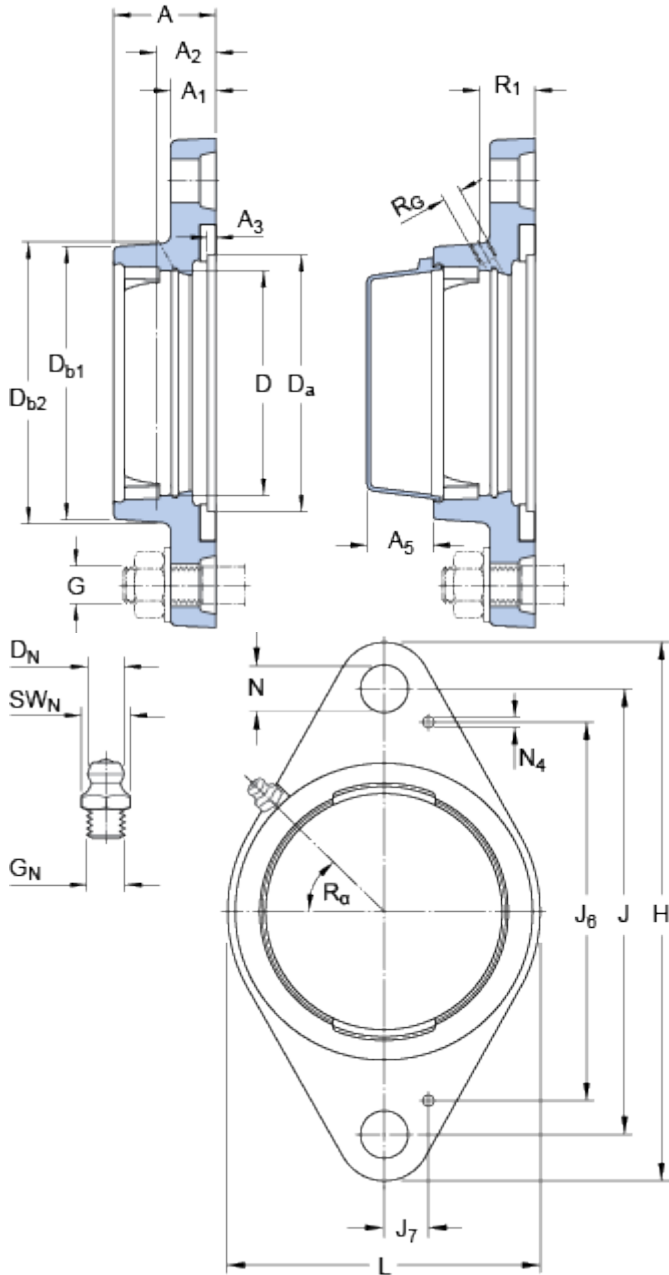

D		90	mm
Da	H11	101.6	mm
Db1		107	mm
Db2		116	mm
A		43	mm
A1		15	mm
A2		28	mm
A3	H14	3.2	mm
A5		29.5	mm
J		157	mm
H		189	mm
L		116	mm
N		18	mm

### Threaded hole

RG		1/4-28 UNF	
R1		28.5	mm
Rα		45	°

### Grease fitting

DN		6.5	mm
SWN		7	mm
GN		1/4-28 SAE-LT	

### Dowel pins

J6		127	mm
J7		20	mm
N4		2	mm

## Mass

Mass housing		1.3	kg
--------------	--	-----	----

## Mounting information

Recommended diameter for attachment bolts, mm	G	16	mm
Recommended diameter for attachment bolts, inch	G	0.625	in

## Appropriate products

End cover		ECY 210	
-----------	--	---------	--

