

FYTB 508 M

Dimensions

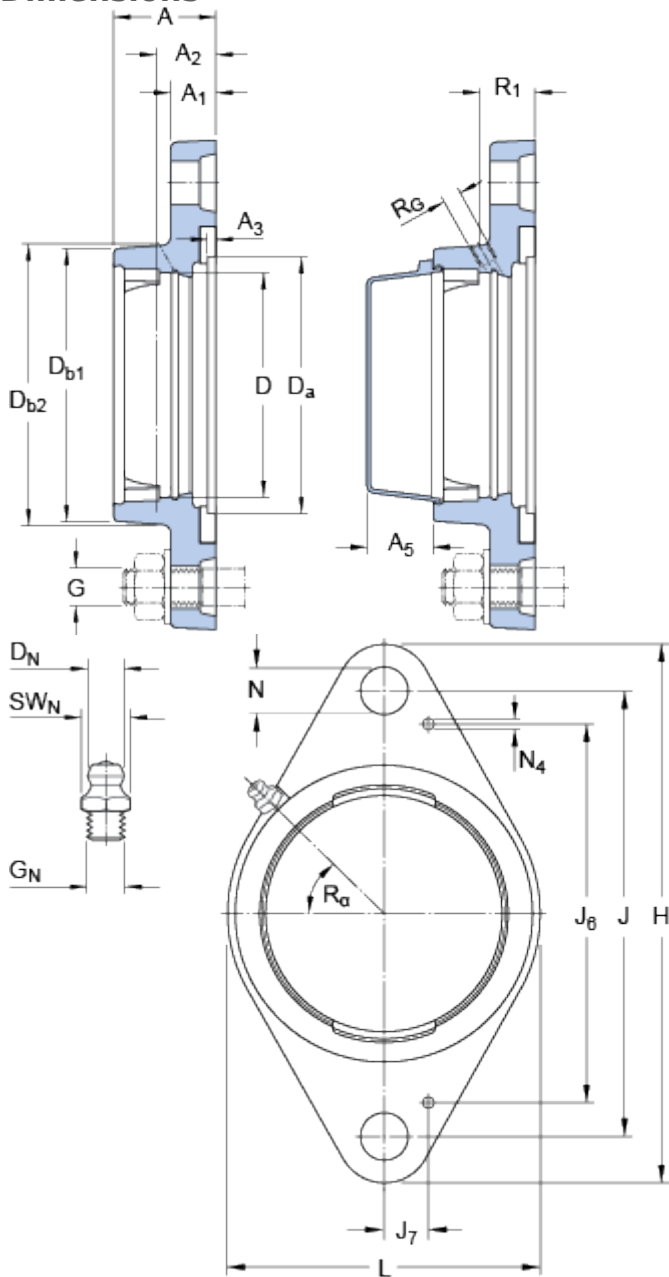

D		80	mm
D _a	H11	88.9	mm
D _{b1}		98	mm
D _{b2}		102	mm
A		38.5	mm
A ₁		14	mm
A ₂		24	mm
A ₃	H14	3.2	mm
A ₅		23.5	mm
J		143.5	mm
H		171.5	mm
L		102	mm
N		14	mm

Threaded hole

R _G		1/4-28 UNF	
R ₁		24.5	mm
R _α		45	°

Grease fitting

D _N		6.5	mm
SW _N		7	mm
G _N		1/4-28 SAE-LT	

Dowel pins

J ₆		115.5	mm
J ₇		16	mm
N ₄		2	mm

Mass

Mass housing	0.96	kg
--------------	------	----

Mounting information

Recommended diameter for attachment bolts, mm	G	12	mm
Recommended diameter for attachment bolts, inch	G	0.5	in

Appropriate products

End cover	ECY 208
-----------	---------

