

FYTB 40 LF

Housing material

Cast iron

Dimensions

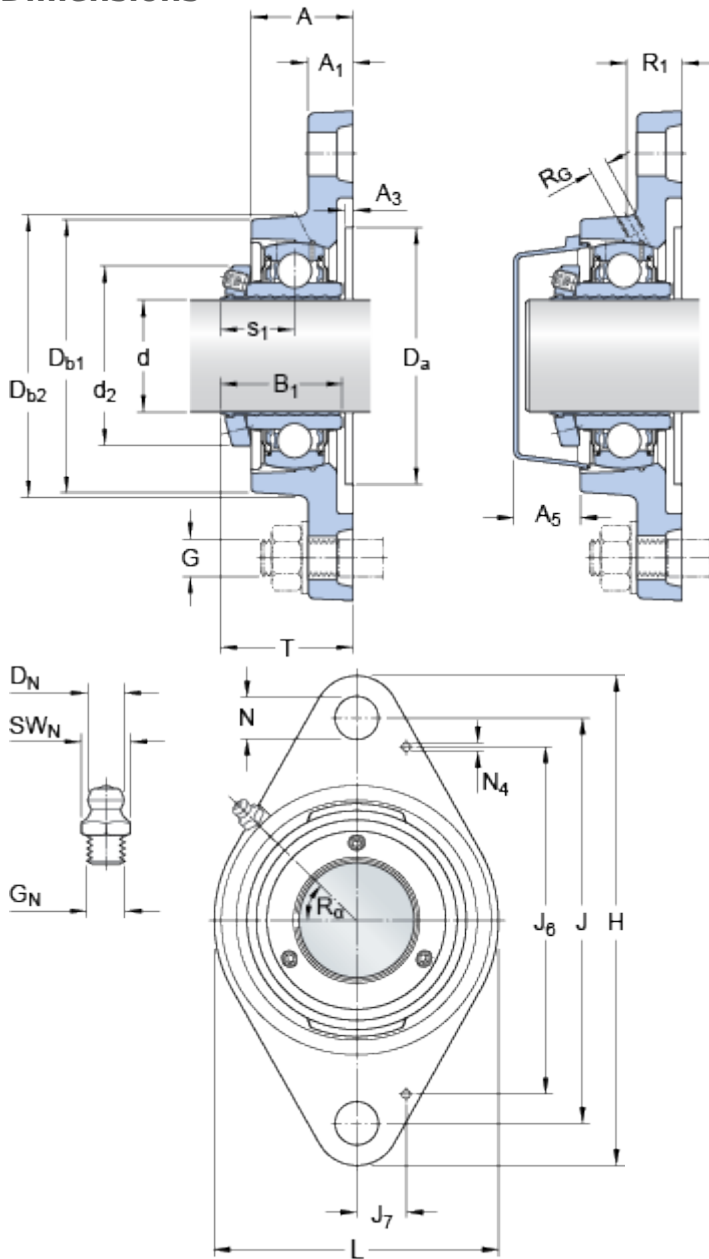

d	40	mm
d ₂	62	mm
D _a	H11 88.9	mm
D _{b1}	98	mm
D _{b2}	102	mm
A	38.5	mm
A ₁	14	mm
A ₃	H14 3.2	mm
A ₅	23.5	mm
B ₁	42.9	mm
J	143.5	mm
H	171.5	mm
L	102	mm
N	14	mm
s ₁	25.9	mm
T	49.9	mm

Values for B₁ and s₁ before the grub screw is tightened (sleeve and inner ring bore at starting position).

Threaded hole

R _G	1/4-28 UNF
R ₁	24.5 mm
R _α	45 °

Grease fitting

D _N	6.5 mm
SW _N	7 mm
G _N	1/4-28 SAE-LT

Dowel pins

J ₆	115.5 mm
J ₇	16 mm
N ₄	2 mm

Calculation data

Basic dynamic load rating	C	30.7	kN
Basic static load rating	C	19	kN
Fatigue load limit	P _u	0.8	kN
Limiting speed		4800	r/min

Mass

Mass bearing unit		1.55	kg
-------------------	--	------	----

Mounting information

Thread grub screw		G ₂	M6
Hexagonal key size for grub screw		N	3 mm
Recommended tightening torque for grub screw			7.4 N·m
Recommended diameter for attachment bolts, mm		G	12 mm
Recommended diameter for attachment bolts, inch		G	0.5 in

Included products

Housing	FYTB 508 M
Bearing	YSP 208 SB-2F

Associated products

End cover	ECY 208
-----------	-------------------------