

YET 208-108

Dimensions

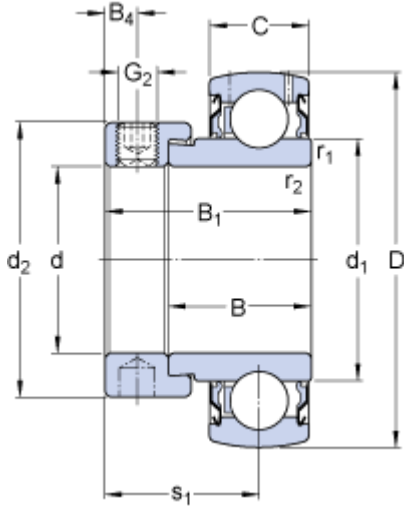

d	38.1	mm
D	80	mm
B_1	43.2	mm
B	29.7	mm
C	21	mm
d_1	≈ 51.8	mm
d_2	56.5	mm
B_4	6.75	mm
$r_{1,2}$	min. 1	mm
s_1	32.7	mm

Calculation data

Basic dynamic load rating	C	30.7	kN
Basic static load rating	C	19	kN
Fatigue load limit	P_u	0.8	kN
Limiting speed ¹⁾		4800	r/min
Calculation factor	f	14	

Mass

Mass complete bearing		0.64	kg
-----------------------	--	------	----

Mounting information

Thread grub screw	G_2	3/8-24 UNF	
Hexagonal key size for grub screw	N	4.763	mm
Recommended tightening torque for grub screw		16.5	N·m

Associated products

Rubber seating ring		RIS 208 A	
---------------------	--	---------------------------	--