

YEL 209-2F

Dimensions

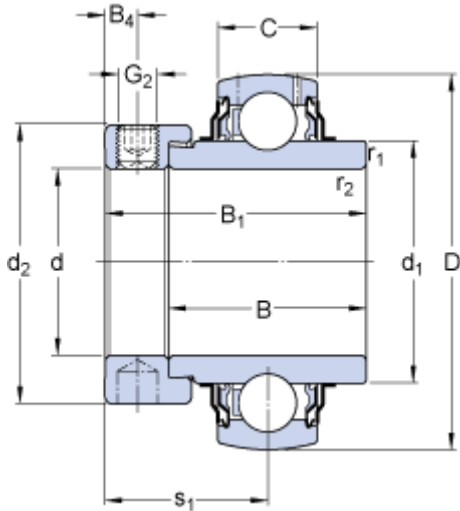

d	45	mm
D	85	mm
B_1	56.3	mm
B	42.8	mm
C	22	mm
d_1	≈ 56.8	mm
d_2	62	mm
B_4	6.75	mm
$r_{1,2}$	min. 1	mm
s_1	34.9	mm

Calculation data

Basic dynamic load rating	C	33.2	kN
Basic static load rating	C	21.6	kN
Fatigue load limit	P_u	0.915	kN
Limiting speed ¹⁾		4300	r/min
Calculation factor	f	14	

Mass

Mass complete bearing		0.79	kg
-----------------------	--	------	----

Mounting information

Thread grub screw	G_2	M10x1	
Hexagonal key size for grub screw	N	5	mm
Recommended tightening torque for grub screw		16.5	N·m