

# YAR 209-110-2F

## Dimensions

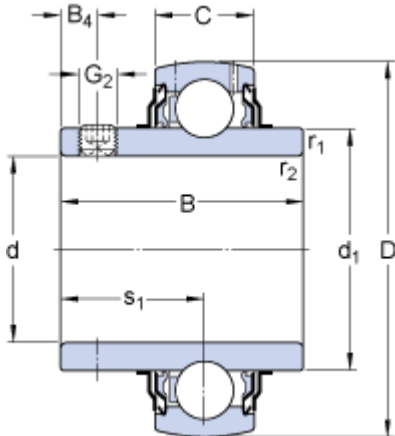

$d$		41.275	mm
$D$		85	mm
$B$		49.2	mm
$C$		22	mm
$d_1$	$\approx$	56.8	mm
$B_4$		8	mm
$r_{1,2}$	min.	1	mm
$s_1$		30.2	mm

## Calculation data

Basic dynamic load rating	$C$	33.2	kN
Basic static load rating	$C$	21.6	kN
Fatigue load limit	$P_u$	0.915	kN
Limiting speed <sup>1)</sup>		4300	r/min
Calculation factor	$f$	14	

## Mass

Mass complete bearing		0.77	kg
-----------------------	--	------	----

## Mounting information

Thread grub screw	$G_2$	5/16-24 UNF	
Hexagonal key size for grub screw	$N$	3.969	mm
Recommended tightening torque for grub screw		6.5	N·m