

YAR 205-2RF

Dimensions

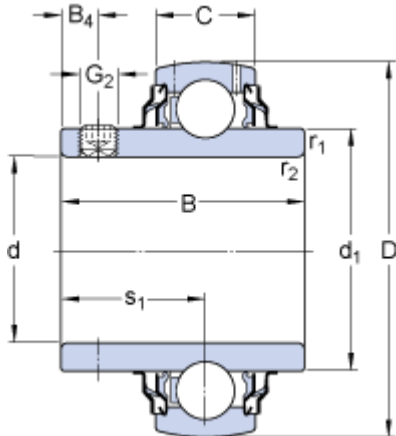

d	25	mm
D	52	mm
B	34.1	mm
C	15	mm
d ₁	≈ 33.74	mm
B ₄	5	mm
r _{1,2}	min. 0.6	mm
s ₁	19.8	mm

Calculation data

Basic dynamic load rating	C	14	kN
Basic static load rating	C	7.8	kN
Fatigue load limit	P _u	0.335	kN
Limiting speed ¹⁾		4300	r/min
Calculation factor	f	14	

Mass

Mass complete bearing		0.19	kg
-----------------------	--	------	----

Mounting information

Thread grub screw	G ₂	M6x0.75
Hexagonal key size for grub screw	N	3 mm
Recommended tightening torque for grub screw		4 N·m

Associated products

Rubber seating ring		RIS 205
---------------------	--	-------------------------