

TU 50 FM

Housing material

Cast iron

Dimensions

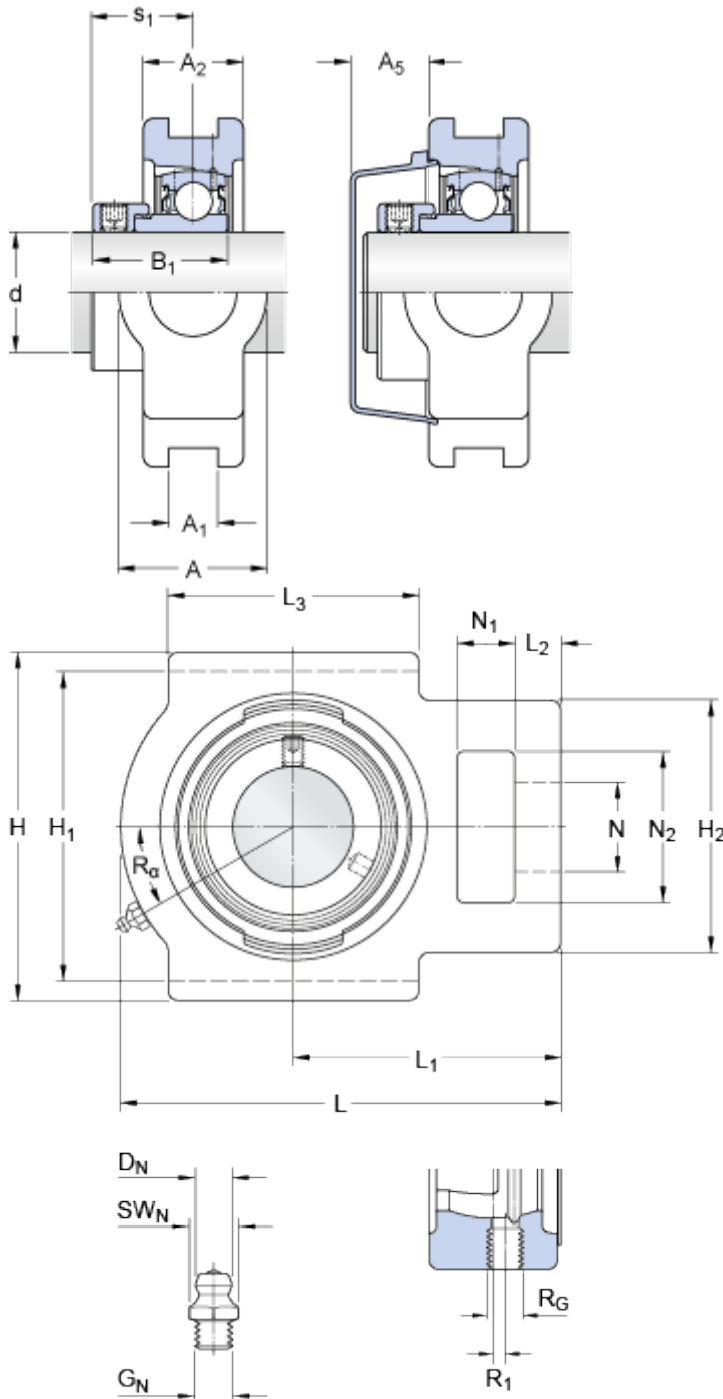

d	50	mm
A	49	mm
A_1	17.5	mm
A_2	36	mm
A_5	29.5	mm
B	30.2	mm
H	117	mm
H_1	101	mm
H_2	83	mm
L	149	mm
L_1	90	mm
L_2	16	mm
L_3	86	mm
N	29	mm
N_1	19	mm
N_2	49	mm
s_1	32.7	mm

Threaded hole

R_G	1/4-28 UNF
R_1	4 mm
R_α	30 °

Grease fitting

D_N	6.5 mm
SW_N	7 mm
G_N	1/4-28 SAE-LT

Calculation data

Basic dynamic load rating	C	35.1	kN
Basic static load rating	C	23.2	kN
Fatigue load limit	P_u	0.98	kN
Limiting speed with shaft tolerance h6		4000	r/min

Mass

Mass bearing unit	2.35	kg
-------------------	------	----

Mounting information

Grub (set) screw	G ₂	M10x1	
Hexagonal key size for grub screw	N	5	mm
Recommended tightening torque for grub screw		16.5	N·m

Included products

Housing	TU 510 M
Bearing	YET 210

Assosiated products

End cover	ECY 210
-----------	-------------------------