

# TU 509 M

## Dimensions

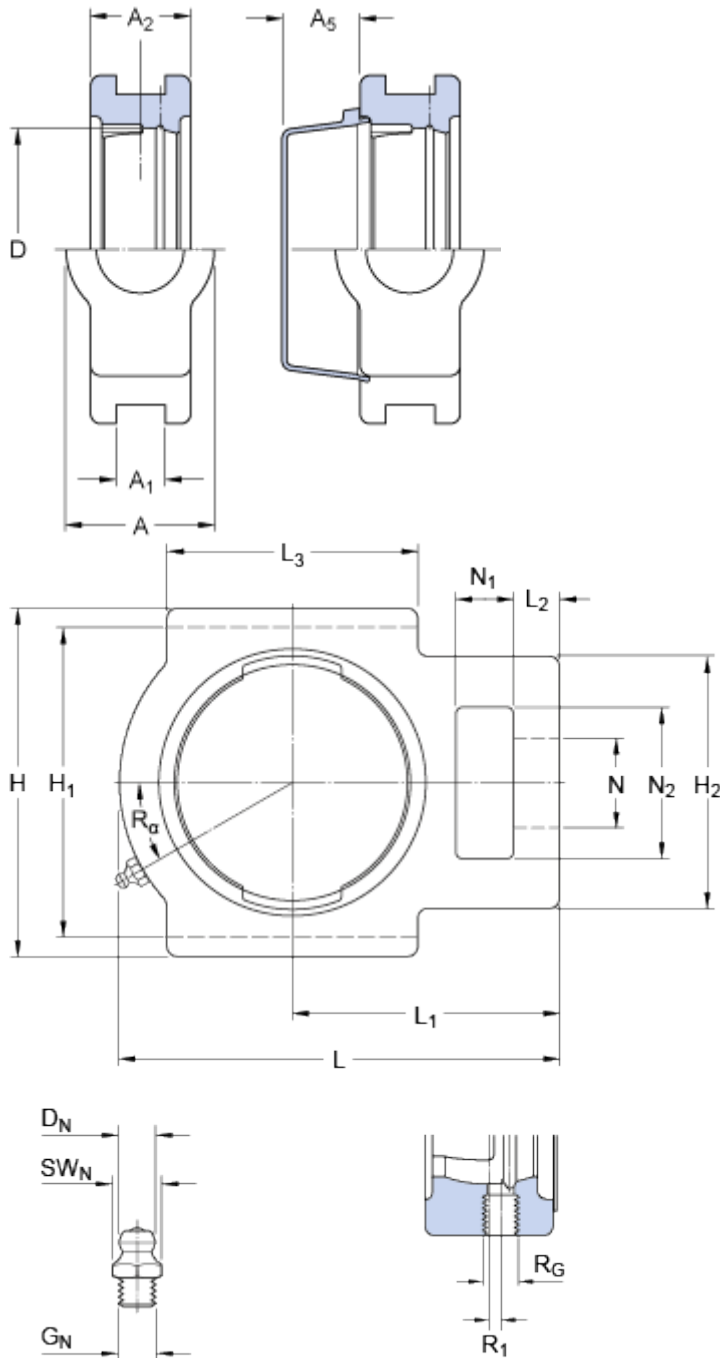

D	85	mm
A	49	mm
A <sub>1</sub>	17.5	mm
A <sub>2</sub>	35	mm
A <sub>5</sub>	23	mm
H	117	mm
H <sub>1</sub>	101	mm
H <sub>2</sub>	83	mm
L	144	mm
L <sub>1</sub>	87	mm
L <sub>2</sub>	15	mm
L <sub>3</sub>	83	mm
N	29	mm
N <sub>1</sub>	19	mm
N <sub>2</sub>	49	mm

## Threaded hole

R <sub>G</sub>	1/4-28 UNF
R <sub>1</sub>	4.5 mm
R <sub>α</sub>	30 °

## Grease fitting

D <sub>N</sub>	6.5	mm
SW <sub>N</sub>	7	mm
G <sub>N</sub>	1/4-28 SAE-LT	

## Mass

Mass housing	1.65	kg
--------------	------	----

## Appropriate products

End cover	<a href="#">ECY 209</a>
-----------	-------------------------

