

# SY 65 TF

Material

Cast iron

## Dimensions

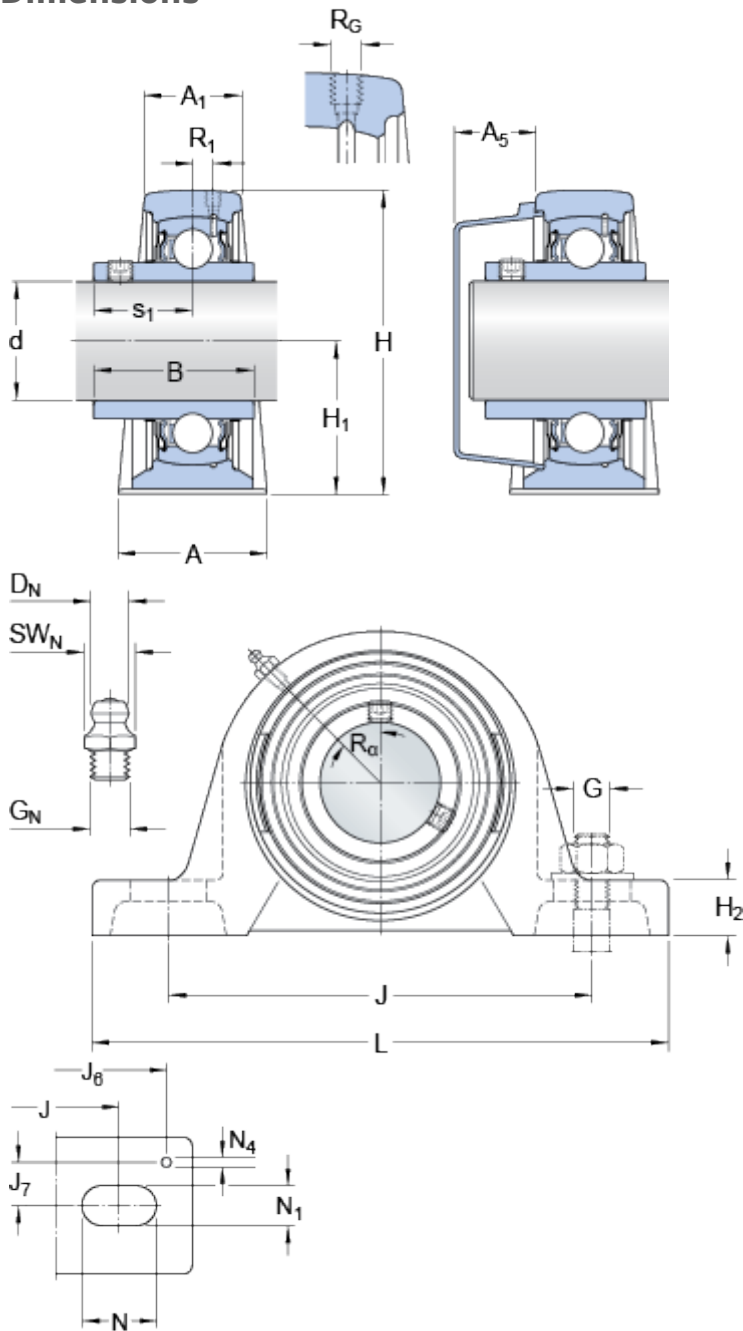

d	65	mm
A	65	mm
A <sub>1</sub>	44	mm
A <sub>5</sub>	35.5	mm
B	68.3	mm
H	150	mm
H <sub>1</sub>	76.2	mm
H <sub>2</sub>	29	mm
J	203	mm
J	max. 216	mm
J	min. 190	mm
L	258	mm
N	35	mm
N <sub>1</sub>	22	mm
s <sub>1</sub>	42.9	mm

### Threaded hole

R <sub>G</sub>	1/4-28 UNF
R <sub>1</sub>	5.5 mm
R <sub>α</sub>	45 °

### Grease fitting

D <sub>N</sub>	6.5 mm
SW <sub>N</sub>	7 mm
G <sub>N</sub>	1/4-28 SAE-LT

### Dowel pins

J <sub>6</sub>	238 mm
J <sub>7</sub>	22.5 mm
N <sub>4</sub>	4 mm

## Calculation data

Basic dynamic load rating	C	57.2	kN
Basic static load rating	C	40	kN
Fatigue load limit	P <sub>u</sub>	1.7	kN
Limiting speed		3000	r/min

(with shaft tolerance h6)

## Mass

---

Mass bearing unit	5.35	kg
-------------------	------	----

## Mounting information

---

Hexagonal key size for grub screw	N	5	mm
Recommended tightening torque for grub screw		16.5	N·m
Recommended diameter for attachment bolts, mm	G	20	mm
Recommended diameter for attachment bolts, inch	G	0.75	in

## Included products

---

Housing	<a href="#">SY 513 M</a>
Bearing	<a href="#">YAR 213-2F</a>

## Associated products

---

End cover	<a href="#">ECY 213</a>
-----------	-------------------------