

SY 60 TF

Material

Cast iron

Dimensions

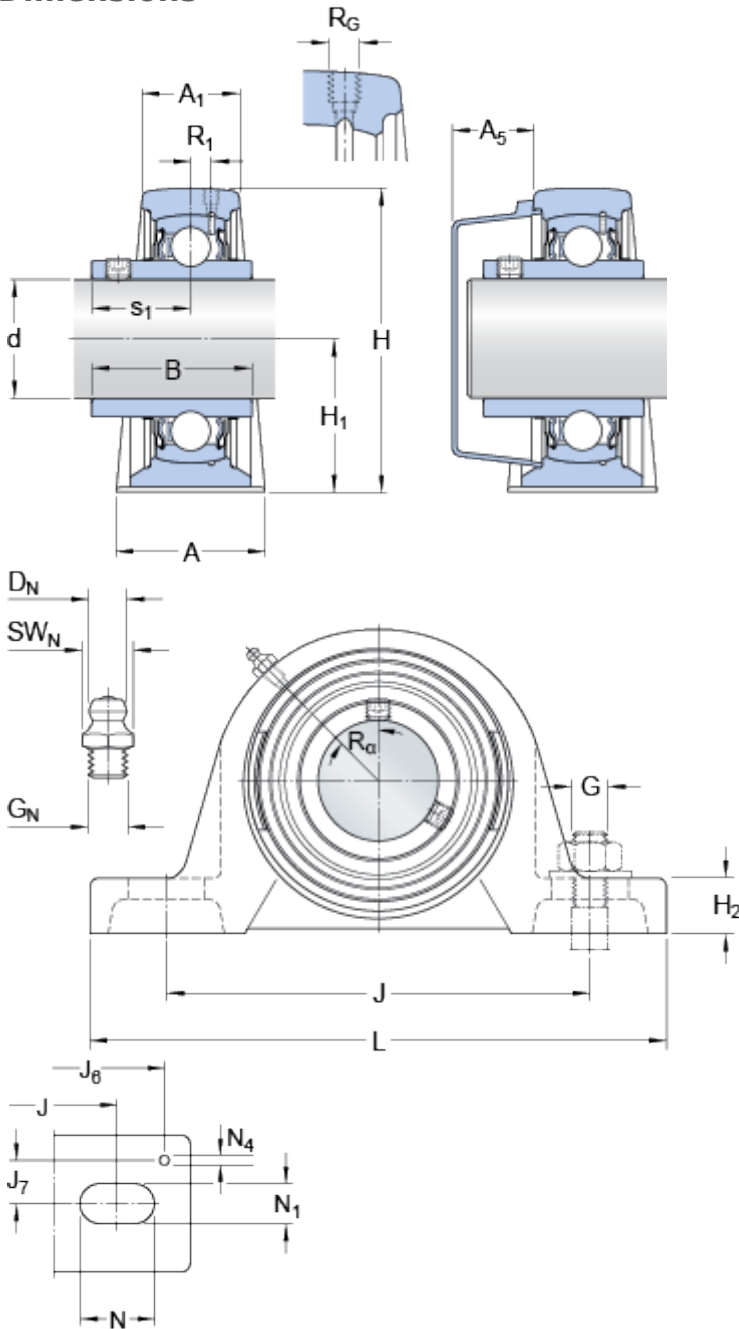

d	60	mm
A	60	mm
A ₁	42	mm
A ₅	35.5	mm
B	65.1	mm
H	137.5	mm
H ₁	69.9	mm
H ₂	26.5	mm
J	190.5	mm
J	max. 202	mm
J	min. 179	mm
L	240	mm
N	29.5	mm
N ₁	18	mm
s ₁	39.7	mm

Threaded hole

R _G	1/4-28 UNF
R ₁	5.5 mm
R _α	45 °

Grease fitting

D _N	6.5 mm
SW _N	7 mm
G _N	1/4-28 SAE-LT

Dowel pins

J ₆	222 mm
J ₇	21 mm
N ₄	4 mm

Calculation data

Basic dynamic load rating	C	52.7	kN
Basic static load rating	C	36	kN
Fatigue load limit	P _u	1.53	kN
Limiting speed		3400	r/min

(with shaft tolerance h6)

Mass

Mass bearing unit	4.35	kg
-------------------	------	----

Mounting information

Hexagonal key size for grub screw	N	5	mm
Recommended tightening torque for grub screw		16.5	N·m
Recommended diameter for attachment bolts, mm	G	16	mm
Recommended diameter for attachment bolts, inch	G	0.625	in

Included products

Housing	SY 512 M
Bearing	YAR 212-2F

Associated products

End cover	ECY 212
-----------	-------------------------