

# SY 60 FM

Material

Cast iron

## Dimensions

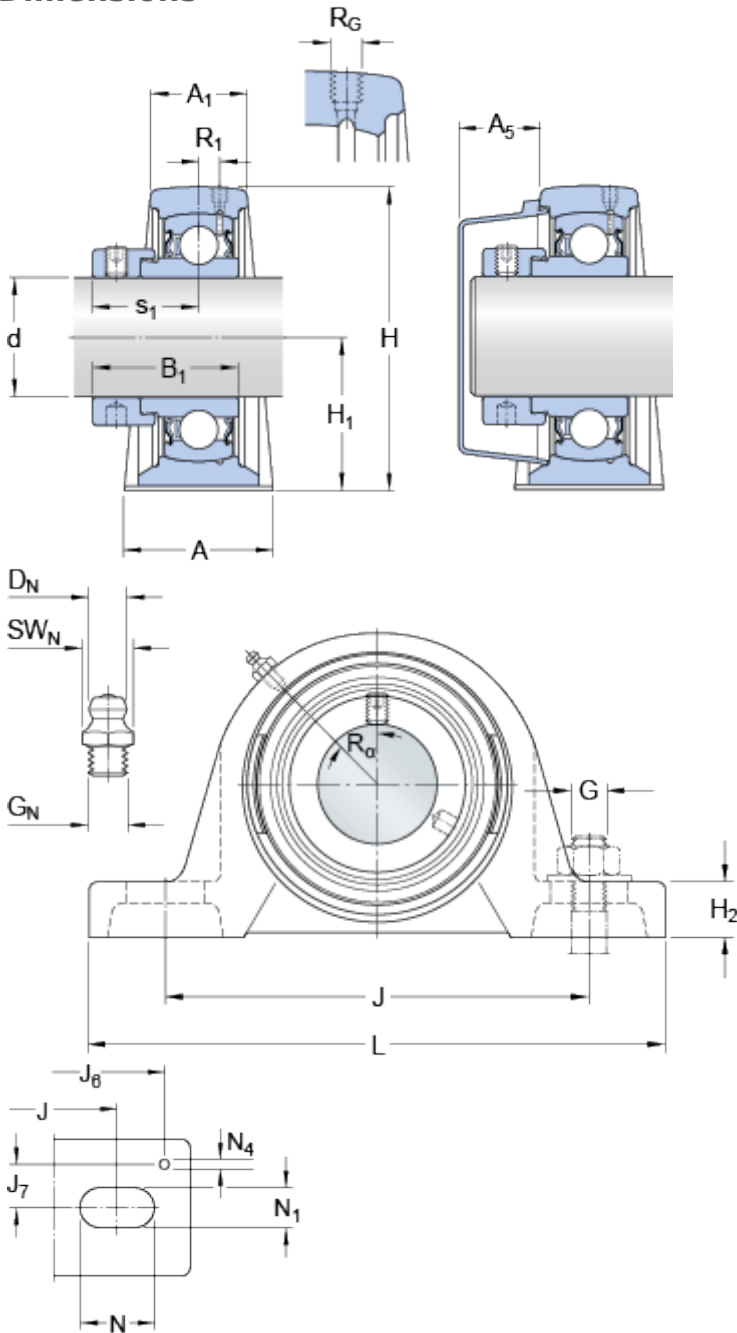

d	60	mm
A	60	mm
A <sub>1</sub>	42	mm
A <sub>5</sub>	35.5	mm
B <sub>1</sub>	53.1	mm
H	137.5	mm
H <sub>1</sub>	69.9	mm
H <sub>2</sub>	26.5	mm
J	190.5	mm
J	max. 202	mm
J	min. 179	mm
L	240	mm
N	29.5	mm
N <sub>1</sub>	18	mm
s <sub>1</sub>	40.1	mm

### Threaded hole

R <sub>G</sub>	1/4-28 UNF
R <sub>1</sub>	5.5 mm
R <sub>α</sub>	45 °

### Grease fitting

D <sub>N</sub>	6.5 mm
SW <sub>N</sub>	7 mm
G <sub>N</sub>	1/4-28 SAE-LT

### Dowel pins

J <sub>6</sub>	222 mm
J <sub>7</sub>	21 mm
N <sub>4</sub>	4 mm

## Calculation data

Basic dynamic load rating	C	52.7	kN
Basic static load rating	C	36	kN
Fatigue load limit	P <sub>u</sub>	1.53	kN
Limiting speed		3400	r/min

(with shaft tolerance h6)

## Mass

---

Mass bearing unit	4.3	kg
-------------------	-----	----

## Mounting information

---

Hexagonal key size for grub screw	N	5	mm
Recommended tightening torque for grub screw		16.5	N·m
Recommended diameter for attachment bolts, mm	G	16	mm
Recommended diameter for attachment bolts, inch	G	0.625	in

## Included products

---

Housing	<a href="#">SY 512 M</a>
Bearing	<a href="#">YET 212</a>

## Associated products

---

End cover	<a href="#">ECY 212</a>
-----------	-------------------------