

SY 55 TF

Material

Cast iron

Dimensions

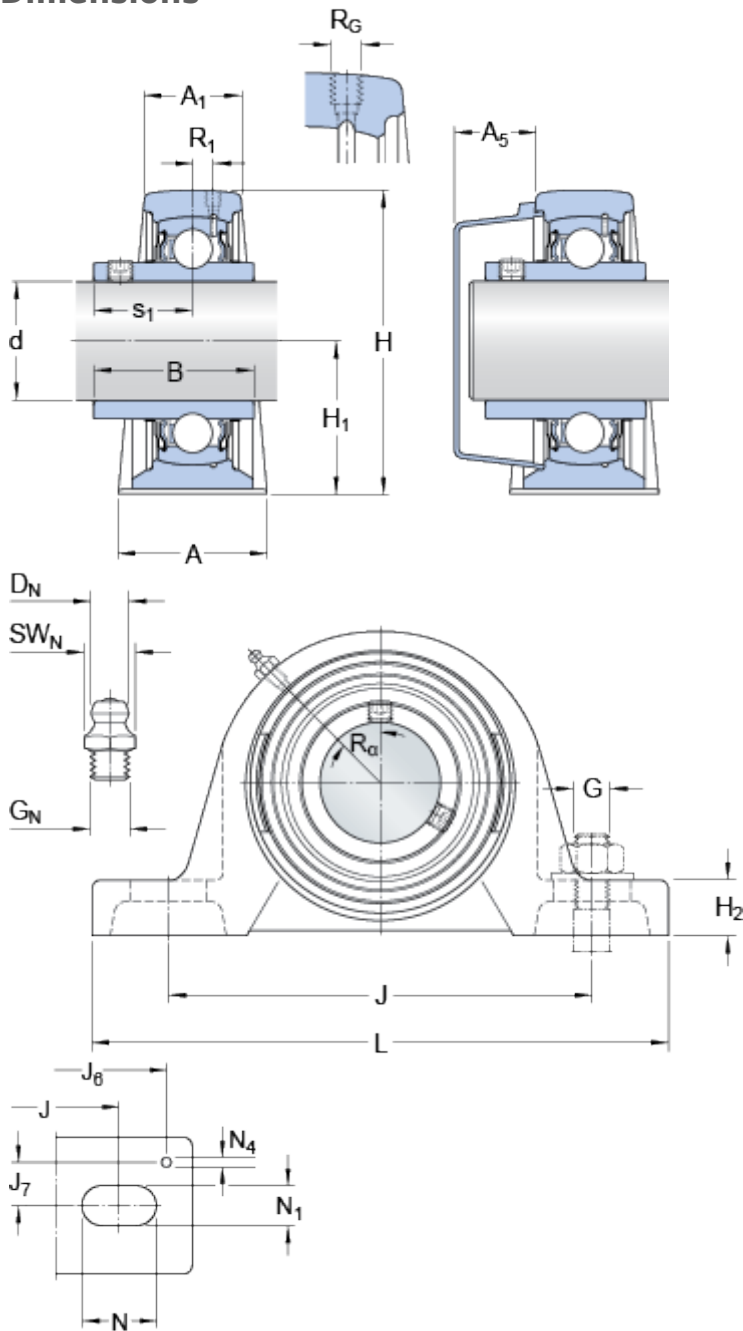

d	55	mm
A	60	mm
A ₁	40	mm
A ₅	34	mm
B	55.6	mm
H	126	mm
H ₁	63.5	mm
H ₂	24	mm
J	171.5	mm
J	max. 181	mm
J	min. 162	mm
L	219	mm
N	27.5	mm
N ₁	18	mm
s ₁	33.4	mm

Threaded hole

R _G	1/4-28 UNF
R ₁	4.5 mm
R _α	45 °

Grease fitting

D _N	6.5 mm
SW _N	7 mm
G _N	1/4-28 SAE-LT

Dowel pins

J ₆	201 mm
J ₇	21 mm
N ₄	4 mm

Calculation data

Basic dynamic load rating	C	43.6	kN
Basic static load rating	C	29	kN
Fatigue load limit	P _u	1.25	kN
Limiting speed		3600	r/min

(with shaft tolerance h6)

Mass

Mass bearing unit	3.3	kg
-------------------	-----	----

Mounting information

Hexagonal key size for grub screw	N	5	mm
Recommended tightening torque for grub screw		16.5	N·m
Recommended diameter for attachment bolts, mm	G	16	mm
Recommended diameter for attachment bolts, inch	G	0.625	in

Included products

Housing	SY 511 M
Bearing	YAR 211-2F

Associated products

End cover	ECY 211
-----------	-------------------------