

SY 513 M

Material

Cast iron

Dimensions

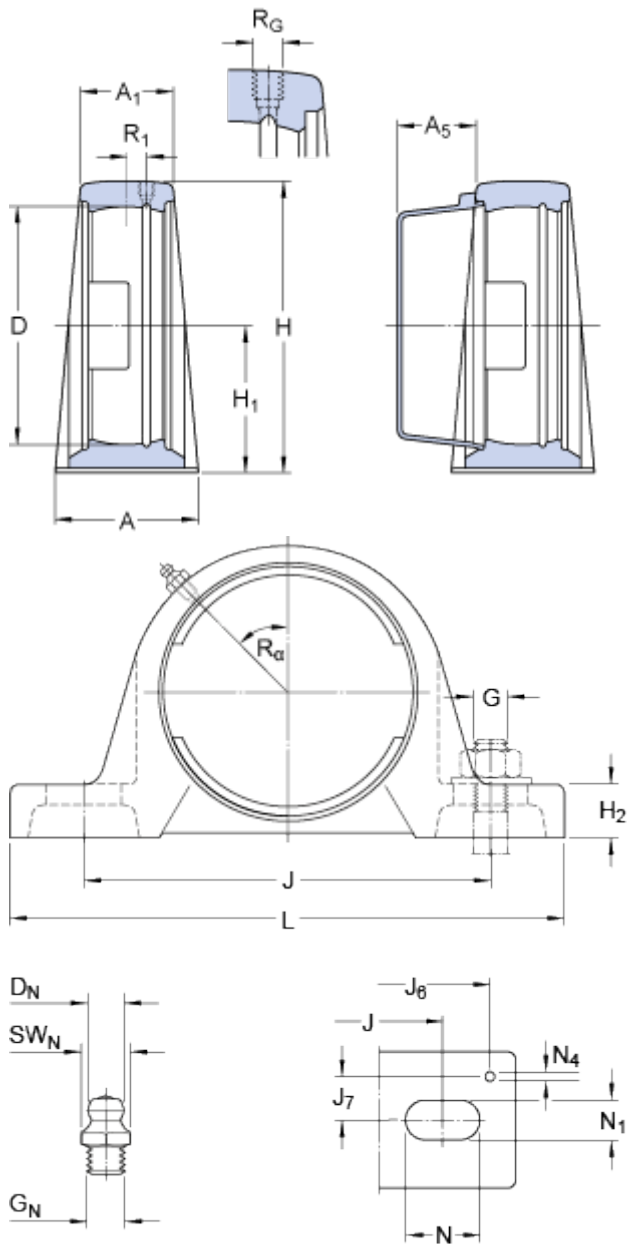

D	120	mm
H ₁	76.2	mm
A	65	mm
A ₁	44	mm
A ₅	35.5	mm
H	150	mm
H ₂	29	mm
J	203	mm
J	max. 216	mm
J	min. 190	mm
L	258	mm
N	35	mm
N ₁	22	mm

Threaded hole

R _G	1/4-28 UNF
R ₁	5.5 mm
R _α	45 °

Grease fitting

D _N	6.5	mm
SW _N	7	mm
G _N	1/4-28 SAE-LT	

Dowel pins

J ₆	238	mm
J ₇	22.5	mm
N ₄	4	mm

Mass

Mass housing

3.65

kg

Mounting information

Recommended diameter for attachment bolts, mm

G 20 mm

Recommended diameter for attachment bolts, inch

G 0.75 in

Appropriate products

Appropriate end cover

[ECY 213](#)

