

SY 50 WF

Material

Cast iron

Dimensions

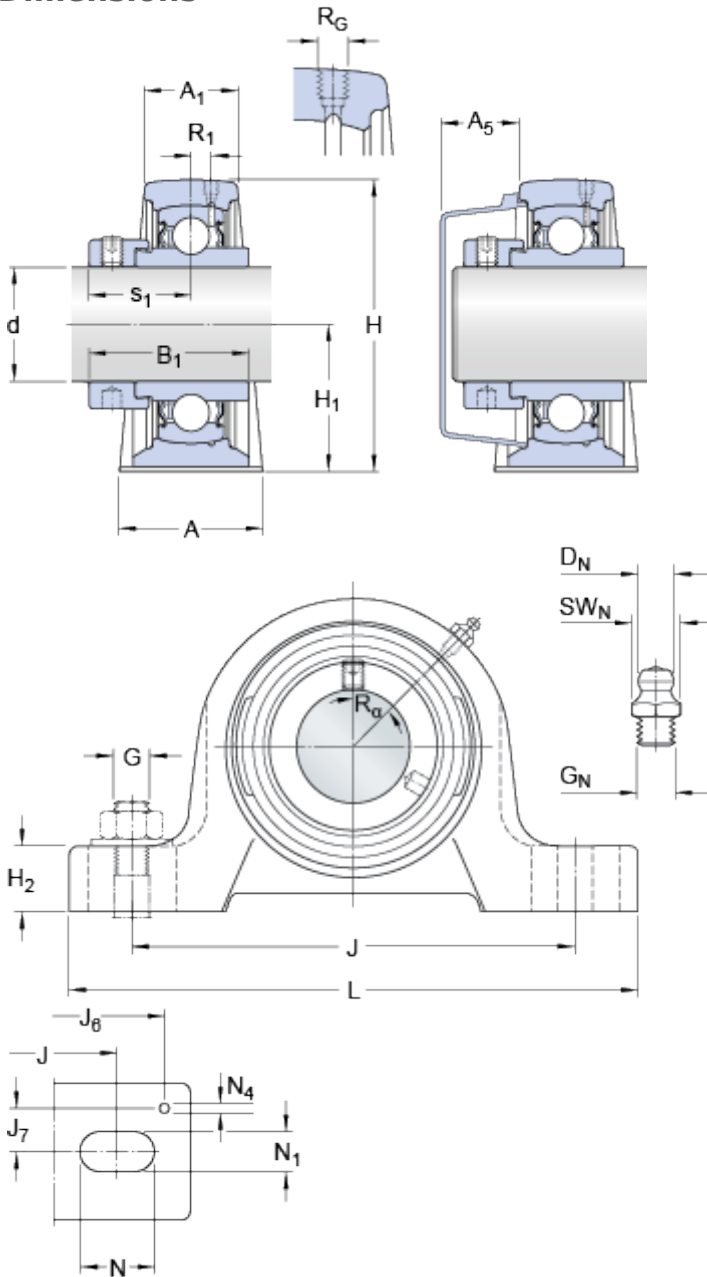

d	50	mm
A	54	mm
A ₁	34	mm
A ₅	29.5	mm
B ₁	62.7	mm
H	114	mm
H ₁	57.2	mm
H ₂	22	mm
J	157	mm
J	max. 165	mm
J	min. 149	mm
L	203	mm
N	26	mm
N ₁	18	mm
s ₁	38.1	mm

Threaded hole

R_G 1/4-28 UNF

R₁ 4 mm

R_α 45 °

Grease fitting

D_N 6.5 mm

SW_N 7 mm

G_N 1/4-28 SAE-LT

Dowel pins

J₆ 187 mm

J₇ 19 mm

N₄ 4 mm

Calculation data

Basic dynamic load rating

C 35.1 kN

Basic static load rating

C 23.2 kN

Fatigue load limit

P_u 0.98 kN

Limiting speed

4000 r/min

(with shaft tolerance h6)

Mass

Mass bearing unit	2.8	kg
-------------------	-----	----

Mounting information

Hexagonal key size for grub screw	N	5	mm
Recommended tightening torque for grub screw		16.5	N·m
Recommended diameter for attachment bolts, mm	G	16	mm
Recommended diameter for attachment bolts, inch	G	0.625	in

Included products

Housing	SY 510 M
Bearing	YEL 210-2F

Associated products

End cover	ECY 210
-----------	-------------------------