

SY 509 M

Material

Cast iron

Dimensions

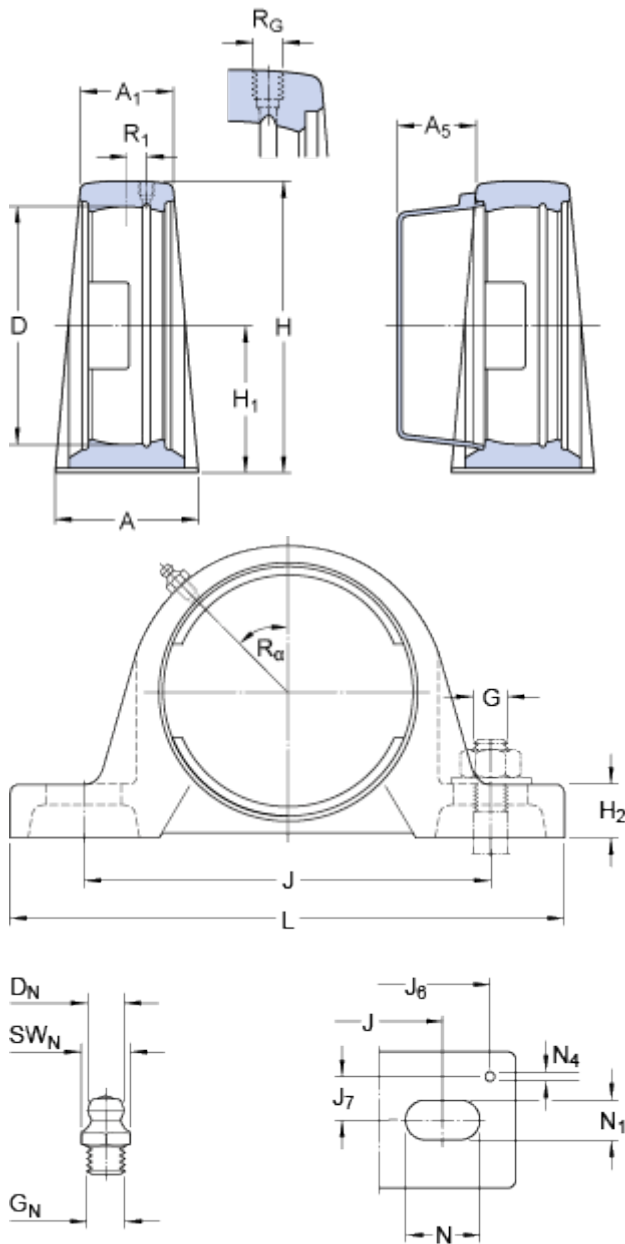

D	85	mm
H ₁	54	mm
A	48	mm
A ₁	32	mm
A ₅	23	mm
H	107	mm
H ₂	21	mm
J	143.5	mm
J	max. 152	mm
J	min. 135	mm
L	187	mm
N	22.5	mm
N ₁	14	mm

Threaded hole

R _G	1/4-28 UNF
R ₁	4 mm
R _α	45 °

Grease fitting

D _N	6.5	mm
SW _N	7	mm
G _N	1/4-28 SAE-LT	

Dowel pins

J ₆	173	mm
J ₇	17	mm
N ₄	4	mm

Mass

Mass housing

1.5

kg

Mounting information

Recommended diameter for attachment bolts, mm

G 12 mm

Recommended diameter for attachment bolts, inch

G 0.5 in

Appropriate products

Appropriate end cover

[ECY 209](#)

