

SY 45 WF

Material

Cast iron

Dimensions

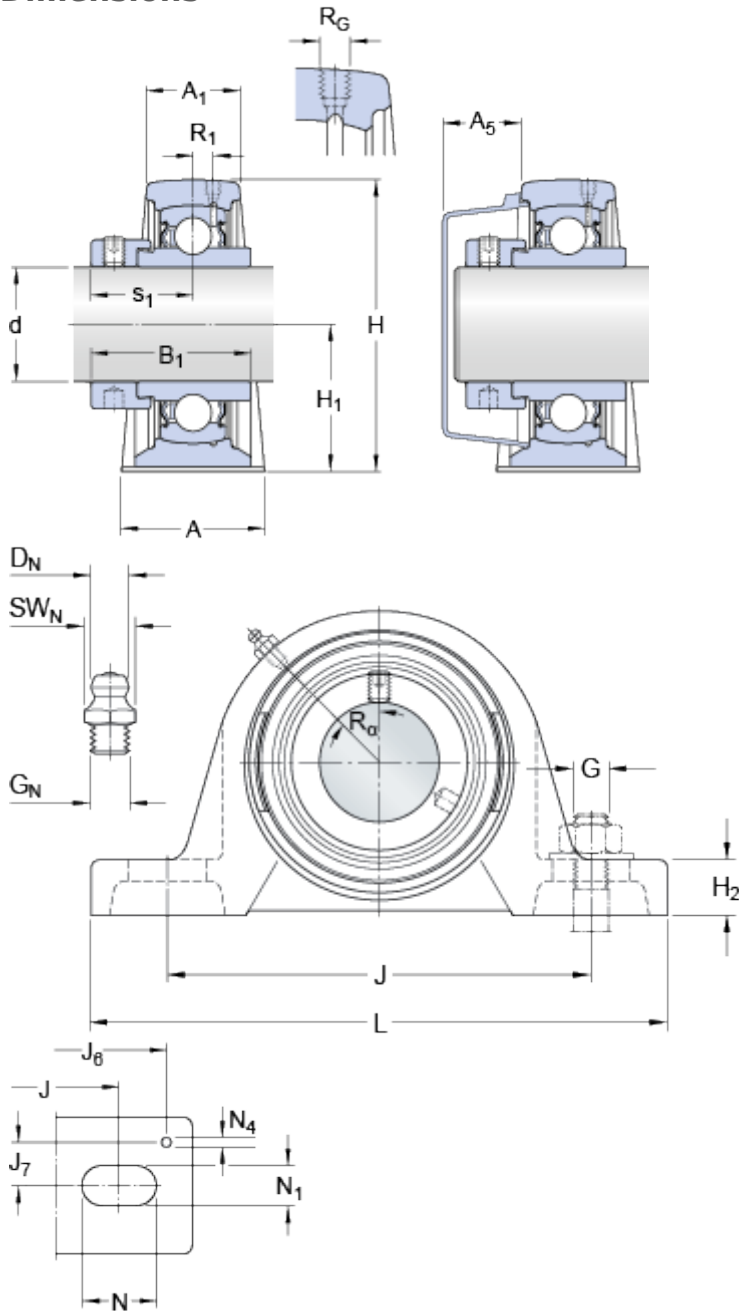

d	45	mm
A	48	mm
A_1	32	mm
A_5	23	mm
B_1	56.3	mm
H	107	mm
H_1	54	mm
H_2	21	mm
J	143.5	mm
J	max. 152	mm
J	min. 135	mm
L	187	mm
N	22.5	mm
N_1	14	mm
s_1	34.9	mm

Threaded hole

R_G	1/4-28 UNF
R_1	4 mm
R_α	45 °

Grease fitting

D_N	6.5 mm
SW_N	7 mm
G_N	1/4-28 SAE-LT

Dowel pins

J_6	173 mm
J_7	17 mm
N_4	4 mm

Calculation data

Basic dynamic load rating	C	33.2	kN
Basic static load rating	C	21.6	kN
Fatigue load limit	P_u	0.915	kN
Limiting speed		4300	r/min

(with shaft tolerance h6)

Mass

Mass bearing unit	2.25	kg
-------------------	------	----

Mounting information

Hexagonal key size for grub screw	N	5	mm
Recommended tightening torque for grub screw		16.5	N·m
Recommended diameter for attachment bolts, mm	G	12	mm
Recommended diameter for attachment bolts, inch	G	0.5	in

Included products

Housing	SY 509 M
Bearing	YEL 209-2F

Associated products

End cover	ECY 209
-----------	-------------------------