

SY 45 FM

Material

Cast iron

Dimensions

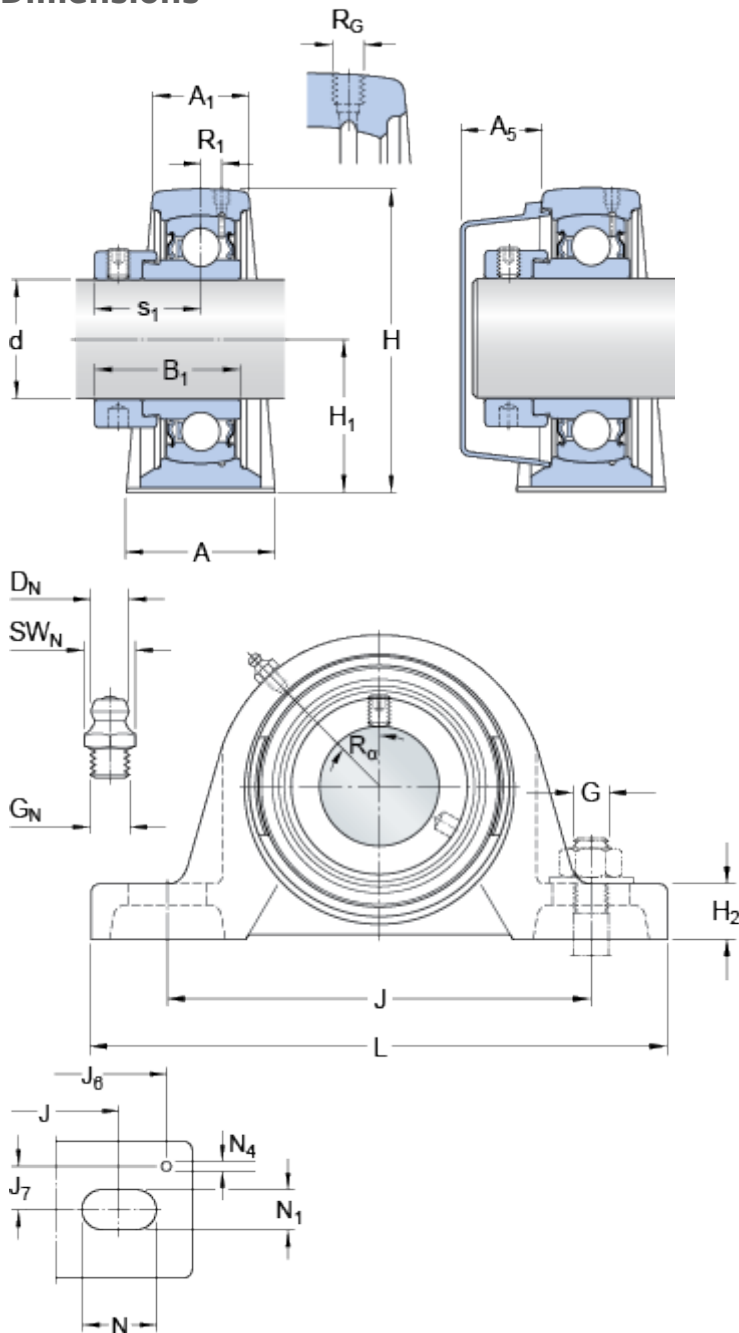

d	45	mm
A	48	mm
A ₁	32	mm
A ₅	23	mm
B ₁	43.7	mm
H	107	mm
H ₁	54	mm
H ₂	21	mm
J	143.5	mm
J	max. 152	mm
J	min. 135	mm
L	187	mm
N	22.5	mm
N ₁	14	mm
s ₁	32.7	mm

Threaded hole

R _G	1/4-28 UNF
R ₁	4 mm
R _α	45 °

Grease fitting

D _N	6.5	mm
SW _N	7	mm
G _N	1/4-28 SAE-LT	

Dowel pins

J ₆	173	mm
J ₇	17	mm
N ₄	4	mm

Calculation data

Basic dynamic load rating	C	33.2	kN
Basic static load rating	C	21.6	kN
Fatigue load limit	P _u	0.915	kN
Limiting speed		4300	r/min

(with shaft tolerance h6)

Mass

Mass bearing unit	2.15	kg
-------------------	------	----

Mounting information

Hexagonal key size for grub screw	N	5	mm
Recommended tightening torque for grub screw		16.5	N·m
Recommended diameter for attachment bolts, mm	G	12	mm
Recommended diameter for attachment bolts, inch	G	0.5	in

Included products

Housing	SY 509 M
Bearing	YET 209

Associated products

End cover	ECY 209
-----------	-------------------------