

SY 40 LF

Material

Cast iron

Dimensions

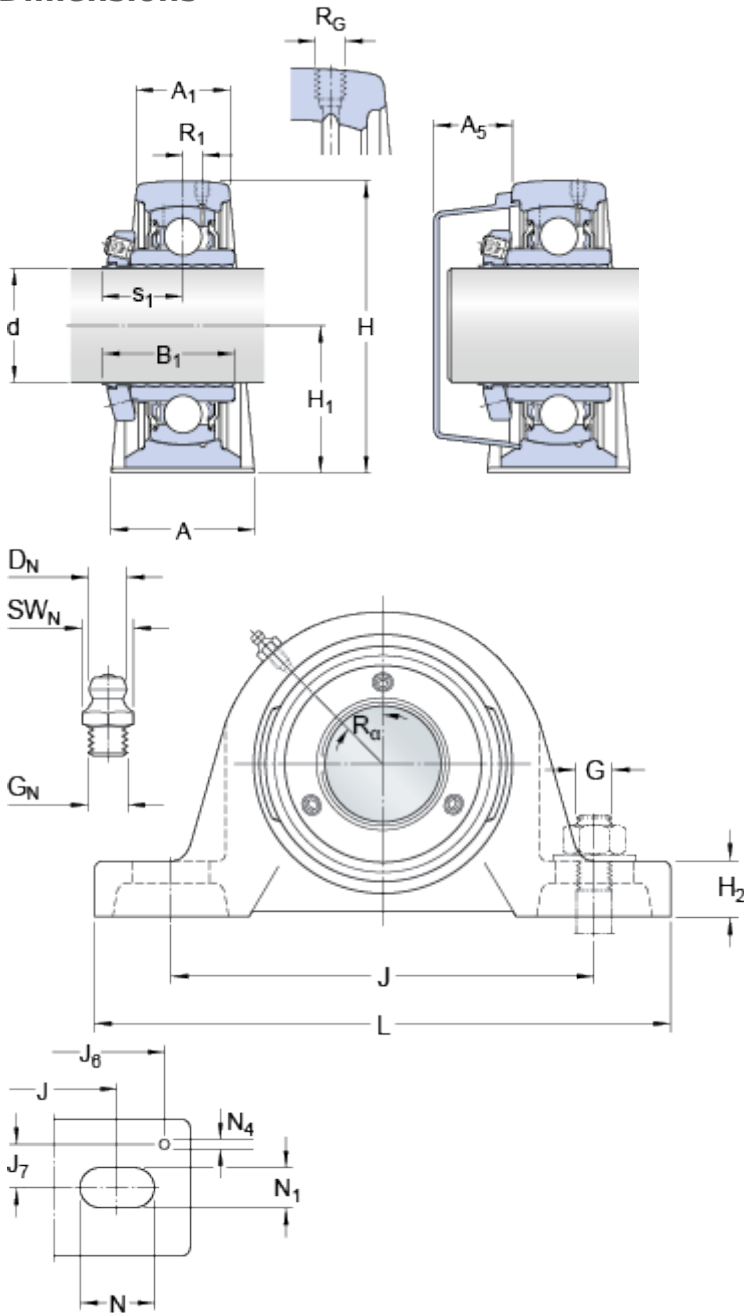

d	40	mm	
A	48	mm	
A ₁	30	mm	
A ₅	23.5	mm	
B ₁	42.9	mm	
H	99	mm	
H ₁	49.2	mm	
H ₂	19	mm	
J	135.5	mm	
J	max.	146	mm
J	min.	125	mm
L	175	mm	
N	24.5	mm	
N ₁	14	mm	
s ₁	25.9	mm	

Values for B₁ and s₁ before the grub screw is tightened (sleeve and inner ring bore at starting position).

Threaded hole

R _G	1/4-28 UNF	
R ₁	3.5	mm
R _α	45	°

Grease fitting

D _N	6.5	mm
SW _N	7	mm
G _N	1/4-28 SAE-LT	

Dowel pins

J ₆	161	mm
J ₇	17	mm
N ₄	4	mm

Calculation data

Basic dynamic load rating

C 30.7 kN

Basic static load rating	C	19	kN
Fatigue load limit	P _u	0.8	kN
Limiting speed		4800	r/min

Mass

Mass bearing unit		1.8	kg
-------------------	--	-----	----

Mounting information

Hexagonal key size for grub screw		N	3	mm
Recommended tightening torque for grub screw			7.4	N·m
Recommended diameter for attachment bolts, mm		G	12	mm
Recommended diameter for attachment bolts, inch		G	0.5	in

Included products

Housing	SY 508 M
Bearing	YSP 208 SB-2F

Associated products

End cover	ECY 208
-----------	-------------------------