

# SY 40 FM

Material

Cast iron

## Dimensions

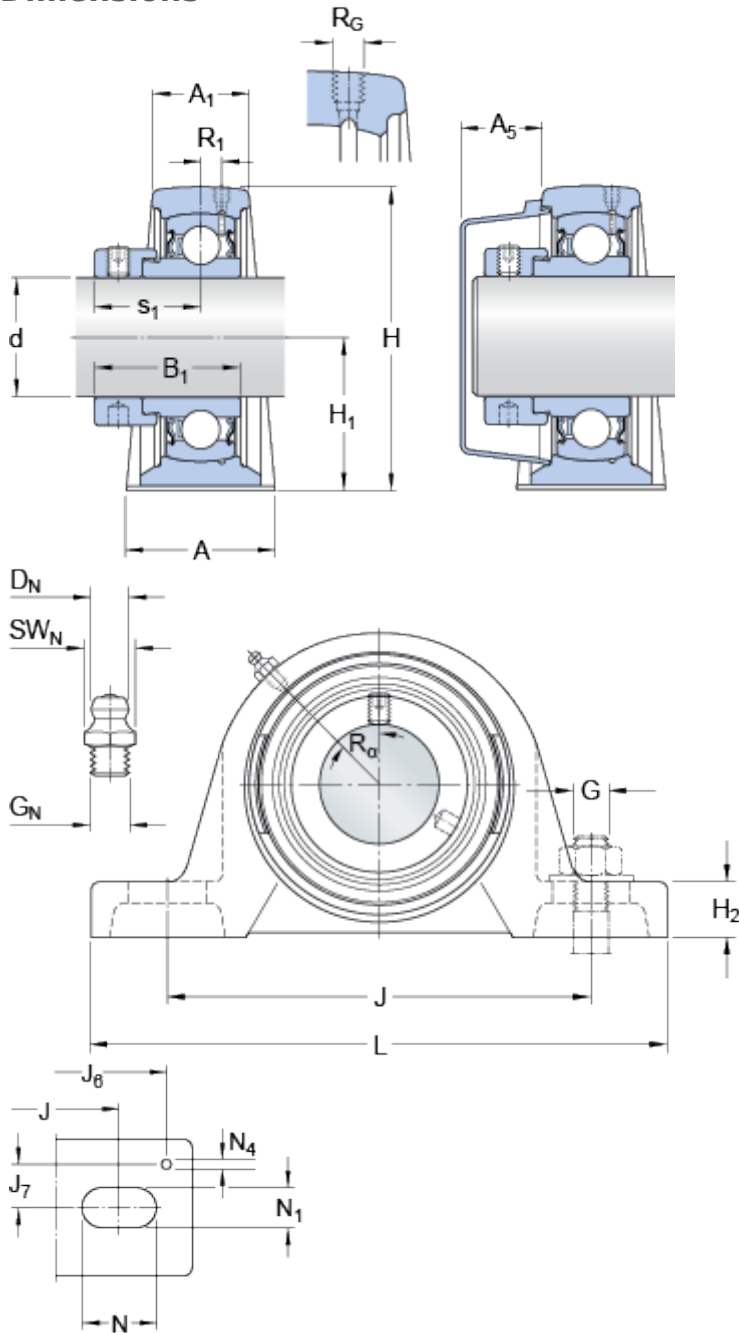

d	40	mm
A	48	mm
A <sub>1</sub>	30	mm
A <sub>5</sub>	23.5	mm
B <sub>1</sub>	43.7	mm
H	99	mm
H <sub>1</sub>	49.2	mm
H <sub>2</sub>	19	mm
J	135.5	mm
J	max. 146	mm
J	min. 125	mm
L	175	mm
N	24.5	mm
N <sub>1</sub>	14	mm
s <sub>1</sub>	33.2	mm

### Threaded hole

R <sub>G</sub>	1/4-28 UNF	
R <sub>1</sub>	3.5	mm
R <sub>α</sub>	45	°

### Grease fitting

D <sub>N</sub>	6.5	mm
SW <sub>N</sub>	7	mm
G <sub>N</sub>	1/4-28 SAE-LT	

### Dowel pins

J <sub>6</sub>	161	mm
J <sub>7</sub>	17	mm
N <sub>4</sub>	4	mm

## Calculation data

Basic dynamic load rating	C	30.7	kN
Basic static load rating	C	19	kN
Fatigue load limit	P <sub>u</sub>	0.8	kN
Limiting speed		4800	r/min

(with shaft tolerance h6)

## Mass

---

Mass bearing unit	1.8	kg
-------------------	-----	----

## Mounting information

---

Hexagonal key size for grub screw	N	5	mm
Recommended tightening torque for grub screw		16.5	N·m
Recommended diameter for attachment bolts, mm	G	12	mm
Recommended diameter for attachment bolts, inch	G	0.5	in

## Included products

---

Housing	<a href="#">SY 508 M</a>
Bearing	<a href="#">YET 208</a>

## Associated products

---

End cover	<a href="#">ECY 208</a>
-----------	-------------------------