

SY 35 TF

Material

Cast iron

Dimensions

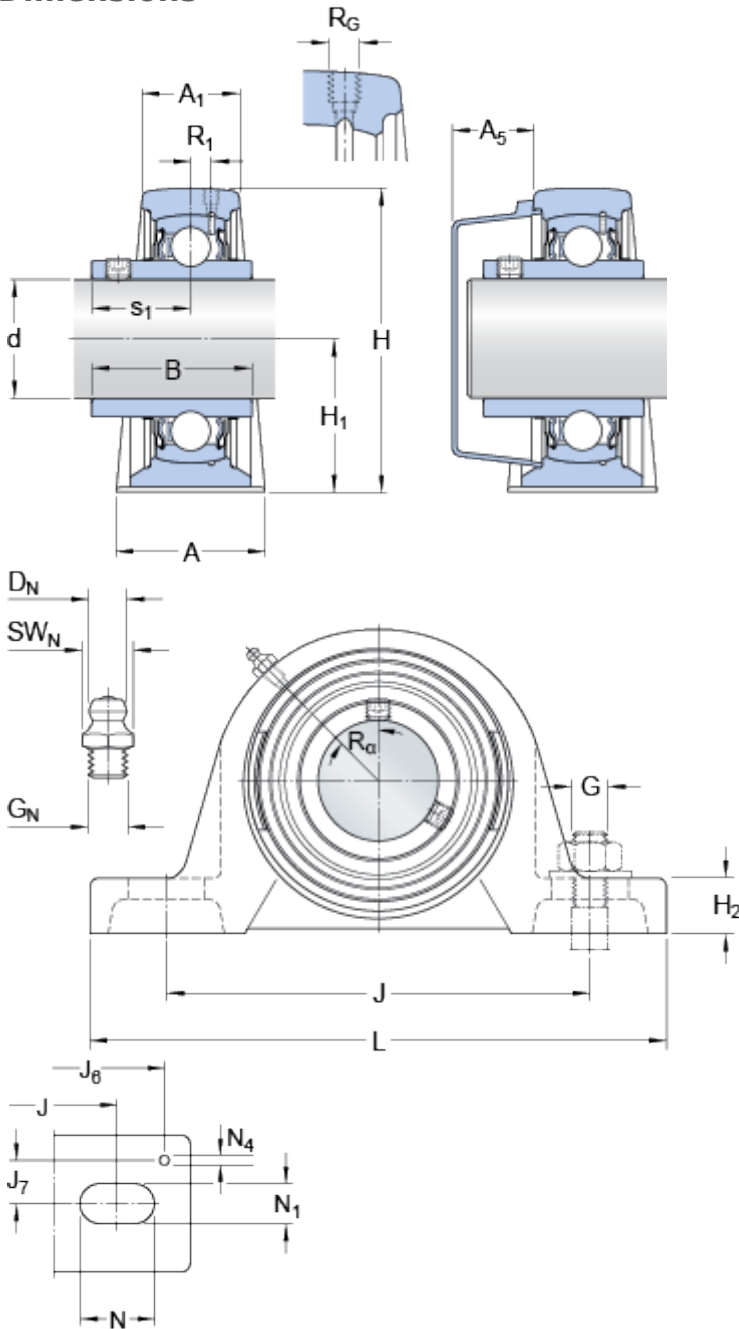

d	35	mm
A	45	mm
A ₁	27	mm
A ₅	22	mm
B	42.9	mm
H	93	mm
H ₁	47.6	mm
H ₂	19	mm
J	126	mm
J	max. 133	mm
J	min. 119	mm
L	160	mm
N	21	mm
N ₁	14	mm
s ₁	25.4	mm

Threaded hole

R _G	1/4-28 UNF
R ₁	3 mm
R _α	45 °

Grease fitting

D _N	6.5	mm
SW _N	7	mm
G _N	1/4-28 SAE-LT	

Dowel pins

J ₆	146	mm
J ₇	15.5	mm
N ₄	4	mm

Calculation data

Basic dynamic load rating	C	25.5	kN
Basic static load rating	C	15.3	kN
Fatigue load limit	P _u	0.655	kN
Limiting speed		5300	r/min

(with shaft tolerance h6)

Mass

Mass bearing unit	1.45	kg
-------------------	------	----

Mounting information

Hexagonal key size for grub screw	N	3	mm
Recommended tightening torque for grub screw		4	N·m
Recommended diameter for attachment bolts, mm	G	12	mm
Recommended diameter for attachment bolts, inch	G	0.5	in

Included products

Housing	SY 507 M
Bearing	YAR 207-2F

Associated products

End cover	ECY 207
-----------	-------------------------