

SY 35 FM

Material

Cast iron

Dimensions

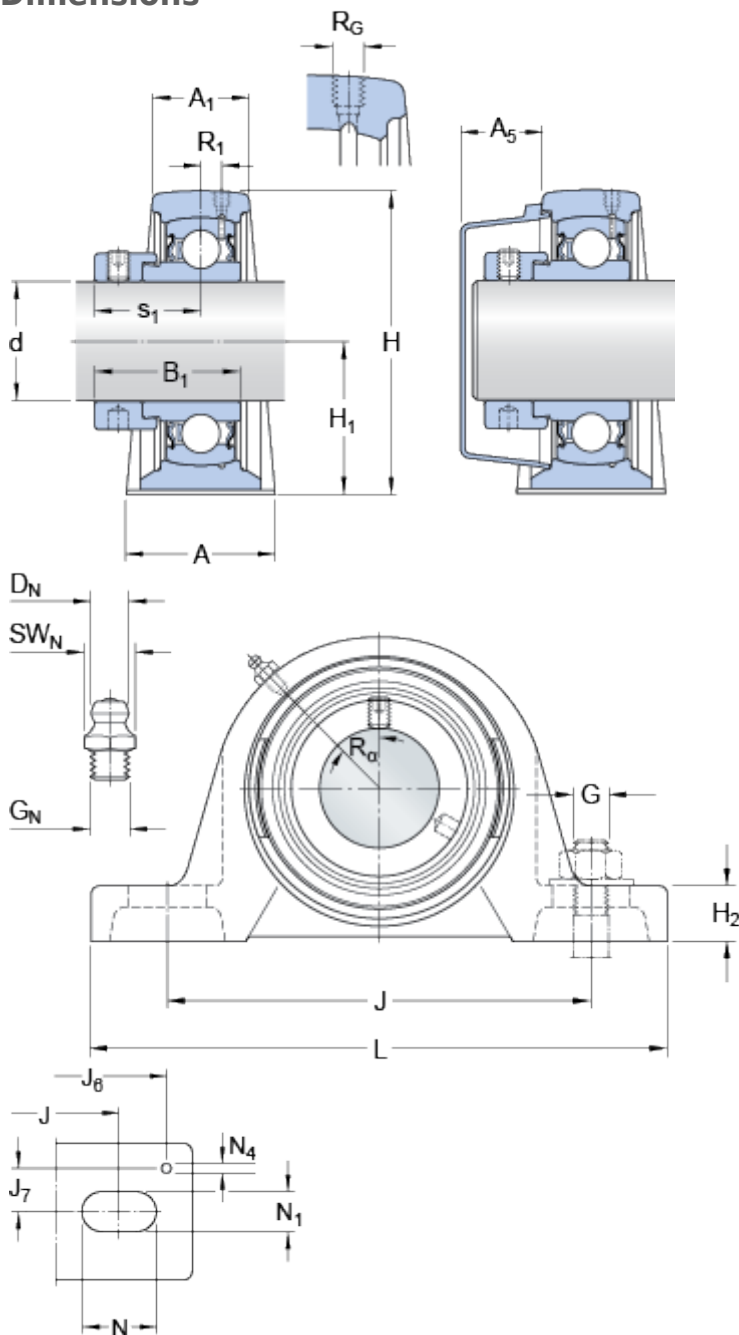

d	35	mm
A	45	mm
A ₁	27	mm
A ₅	22	mm
B ₁	38.9	mm
H	93	mm
H ₁	47.6	mm
H ₂	19	mm
J	126	mm
J	max. 133	mm
J	min. 119	mm
L	160	mm
N	21	mm
N ₁	14	mm
s ₁	29.4	mm

Threaded hole

R_G 1/4-28 UNF

R₁ 3 mm

R_α 45 °

Grease fitting

D_N 6.5 mm

SW_N 7 mm

G_N 1/4-28 SAE-LT

Dowel pins

J₆ 146 mm

J₇ 15.5 mm

N₄ 4 mm

Calculation data

Basic dynamic load rating

C 25.5 kN

Basic static load rating

C 15.3 kN

Fatigue load limit

P_u 0.655 kN

Limiting speed

5300 r/min

(with shaft tolerance h6)

Mass

Mass bearing unit	1.5	kg
-------------------	-----	----

Mounting information

Hexagonal key size for grub screw	N	5	mm
Recommended tightening torque for grub screw		16.5	N·m
Recommended diameter for attachment bolts, mm	G	12	mm
Recommended diameter for attachment bolts, inch	G	0.5	in

Included products

Housing	SY 507 M
Bearing	YET 207

Associated products

End cover	ECY 207
-----------	-------------------------