

SY 30 WF

Material

Cast iron

Dimensions

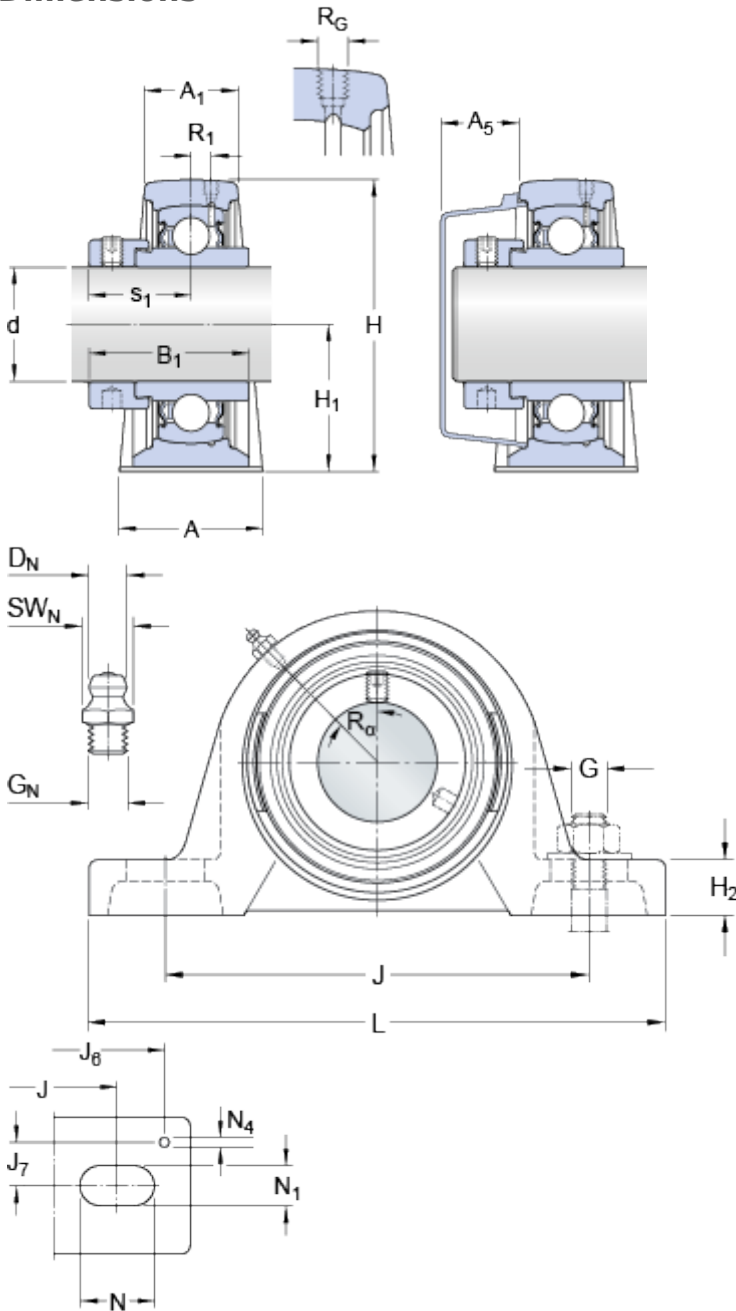

d	30	mm
A	40	mm
A_1	25	mm
A_5	20	mm
B_1	48.4	mm
H	82	mm
H_1	42.9	mm
H_2	17	mm
J	117.5	mm
J	max. 127	mm
J	min. 108	mm
L	152	mm
N	23.5	mm
N_1	14	mm
s_1	30.1	mm

Threaded hole

R_G	1/4-28 UNF
R_1	3 mm
R_α	45 °

Grease fitting

D_N	6.5 mm
SW_N	7 mm
G_N	1/4-28 SAE-LT

Dowel pins

J_6	140 mm
J_7	14 mm
N_4	4 mm

Calculation data

Basic dynamic load rating	C	19.5	kN
Basic static load rating	C	11.2	kN
Fatigue load limit	P_u	0.475	kN
Limiting speed		6300	r/min

(with shaft tolerance h6)

Mass

Mass bearing unit	1.15	kg
-------------------	------	----

Mounting information

Hexagonal key size for grub screw	N	4	mm
Recommended tightening torque for grub screw		6.5	N·m
Recommended diameter for attachment bolts, mm	G	12	mm
Recommended diameter for attachment bolts, inch	G	0.5	in

Included products

Housing	SY 506 M
Bearing	YEL 206-2F

Associated products

End cover	ECY 206
-----------	-------------------------