

SY 30 LF

Material

Cast iron

Dimensions

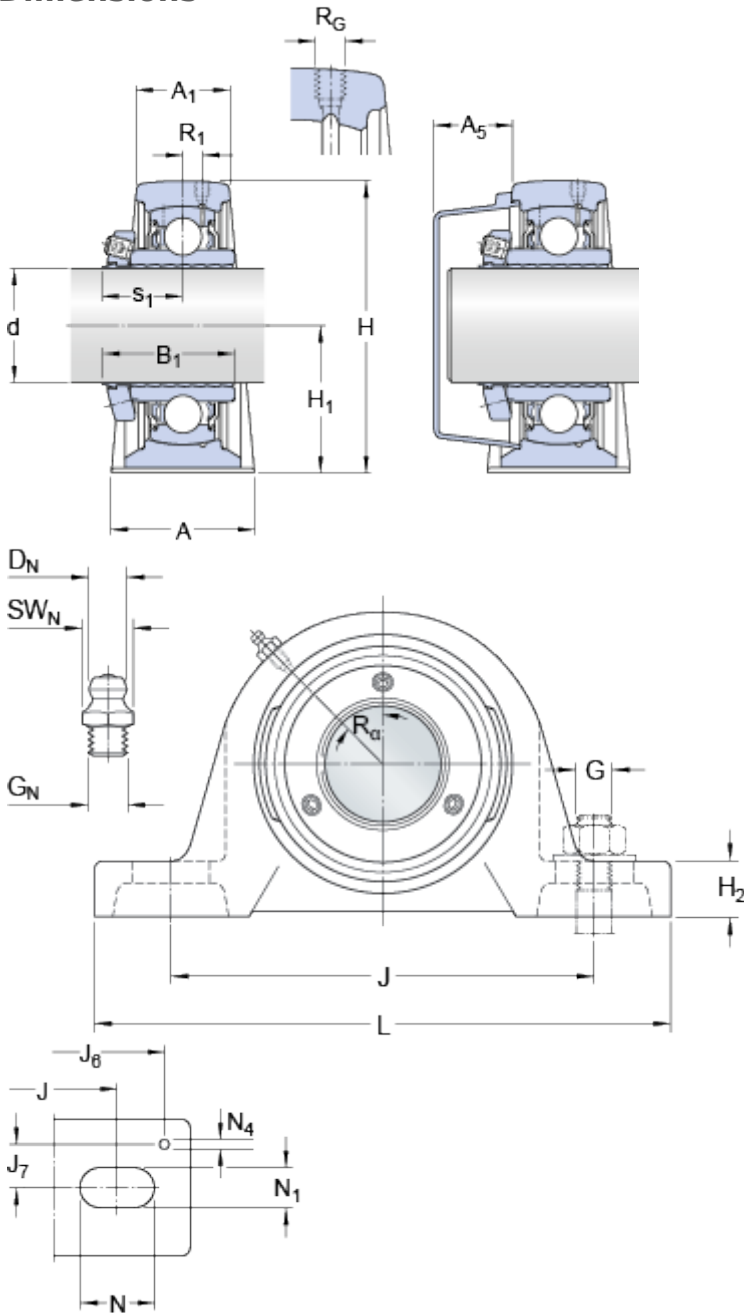

d	30	mm	
A	40	mm	
A ₁	25	mm	
A ₅	20	mm	
B ₁	37	mm	
H	82	mm	
H ₁	42.9	mm	
H ₂	17	mm	
J	117.5	mm	
J	max.	127	mm
J	min.	108	mm
L	152	mm	
N	23.5	mm	
N ₁	14	mm	
s ₁	23	mm	

Values for B₁ and s₁ before the grub screw is tightened (sleeve and inner ring bore at starting position).

Threaded hole

R _G	1/4-28 UNF	
R ₁	3	mm
R _α	45	°

Grease fitting

D _N	6.5	mm
SW _N	7	mm
G _N	1/4-28 SAE-LT	

Dowel pins

J ₆	140	mm
J ₇	14	mm
N ₄	4	mm

Calculation data

Basic dynamic load rating

C 19.5 kN

Basic static load rating	C	11.2	kN
Fatigue load limit	P _u	0.475	kN
Limiting speed		6300	r/min

Mass

Mass bearing unit		1.05	kg
-------------------	--	------	----

Mounting information

Hexagonal key size for grub screw		N	2.5	mm
Recommended tightening torque for grub screw			4.2	N·m
Recommended diameter for attachment bolts, mm		G	12	mm
Recommended diameter for attachment bolts, inch		G	0.5	in

Included products

Housing	SY 506 M
Bearing	YSP 206 SB-2F

Associated products

End cover	ECY 206
-----------	-------------------------