

# SY 30 FM

Material

Cast iron

## Dimensions

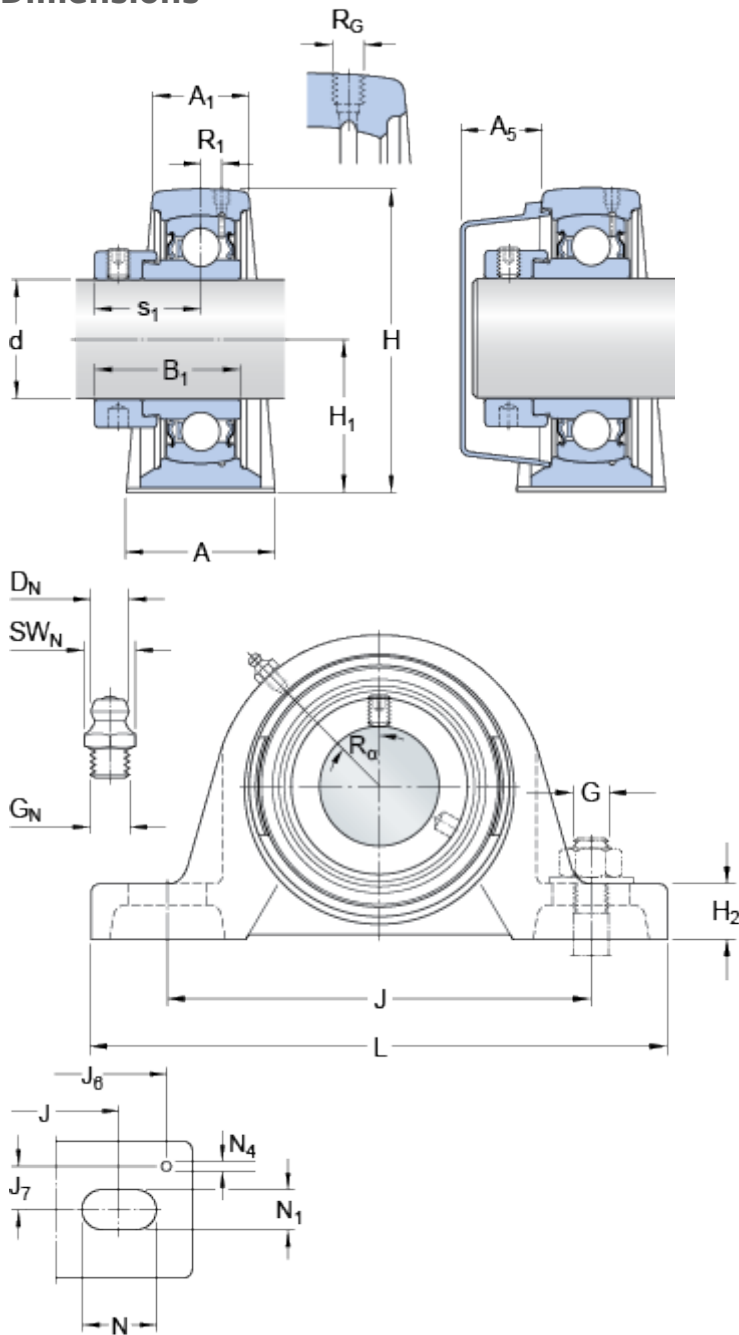

d	30	mm
A	40	mm
A <sub>1</sub>	25	mm
A <sub>5</sub>	20	mm
B <sub>1</sub>	35.7	mm
H	82	mm
H <sub>1</sub>	42.9	mm
H <sub>2</sub>	17	mm
J	117.5	mm
J	max. 127	mm
J	min. 108	mm
L	152	mm
N	23.5	mm
N <sub>1</sub>	14	mm
s <sub>1</sub>	26.7	mm

### Threaded hole

R <sub>G</sub>	1/4-28 UNF
R <sub>1</sub>	3 mm
R <sub>α</sub>	45 °

### Grease fitting

D <sub>N</sub>	6.5	mm
SW <sub>N</sub>	7	mm
G <sub>N</sub>	1/4-28 SAE-LT	

### Dowel pins

J <sub>6</sub>	140	mm
J <sub>7</sub>	14	mm
N <sub>4</sub>	4	mm

## Calculation data

Basic dynamic load rating	C	19.5	kN
Basic static load rating	C	11.2	kN
Fatigue load limit	P <sub>u</sub>	0.475	kN
Limiting speed		6300	r/min

(with shaft tolerance h6)

## Mass

---

Mass bearing unit	1.05	kg
-------------------	------	----

## Mounting information

---

Hexagonal key size for grub screw	N	4	mm
Recommended tightening torque for grub screw		6.5	N·m
Recommended diameter for attachment bolts, mm	G	12	mm
Recommended diameter for attachment bolts, inch	G	0.5	in

## Included products

---

Housing	<a href="#">SY 506 M</a>
Bearing	<a href="#">YET 206</a>

## Associated products

---

End cover	<a href="#">ECY 206</a>
-----------	-------------------------