

SY 25 TF

Material

Cast iron

Dimensions

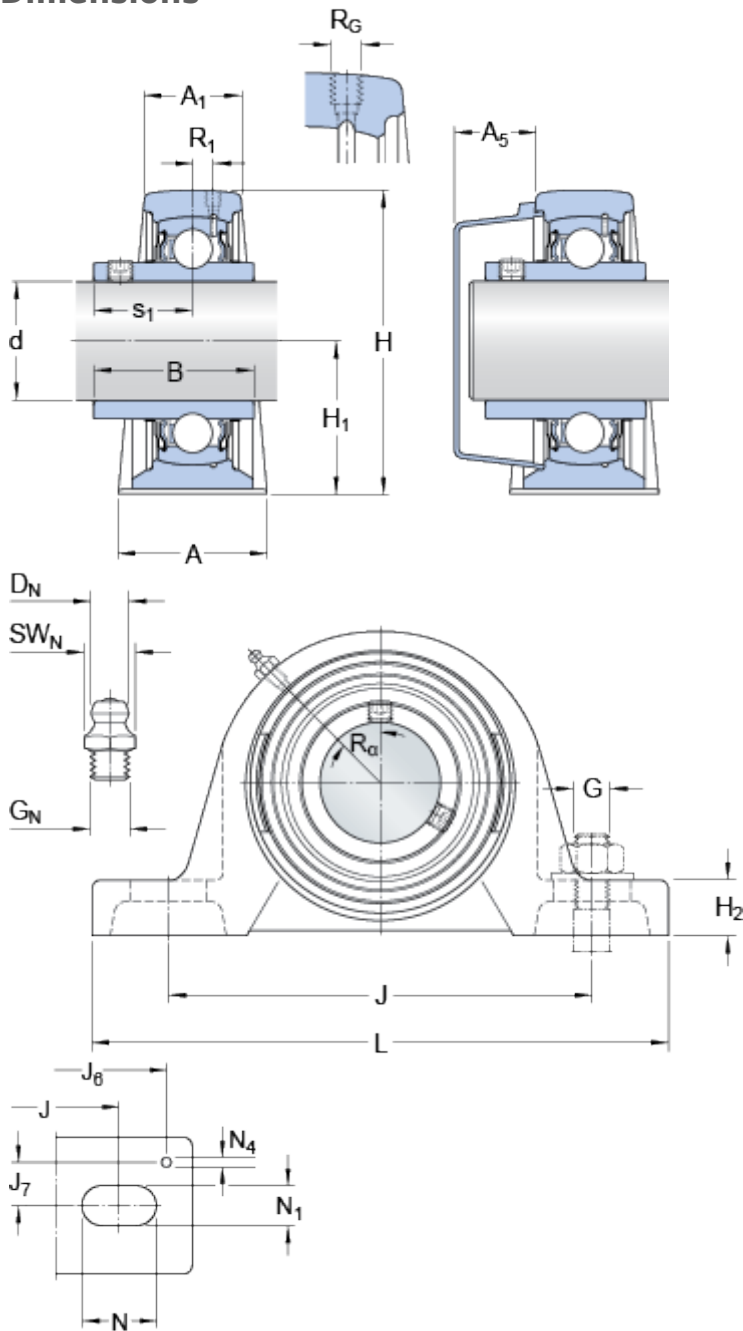

d	25	mm
A	36	mm
A ₁	22	mm
A ₅	18	mm
B	34.1	mm
H	70	mm
H ₁	36.5	mm
H ₂	16	mm
J	102	mm
J	max. 110	mm
J	min. 94	mm
L	130	mm
N	19.5	mm
N ₁	11.5	mm
s ₁	19.8	mm

Threaded hole

R _G	1/4-28 UNF
R ₁	2 mm
R _α	45 °

Grease fitting

D _N	6.5	mm
SW _N	7	mm
G _N	1/4-28 SAE-LT	

Dowel pins

J ₆	120	mm
J ₇	13	mm
N ₄	4	mm

Calculation data

Basic dynamic load rating	C	14	kN
Basic static load rating	C	7.8	kN
Fatigue load limit	P _u	0.335	kN
Limiting speed		7000	r/min

(with shaft tolerance h6)

Mass

Mass bearing unit	0.7	kg
-------------------	-----	----

Mounting information

Hexagonal key size for grub screw	N	3	mm
Recommended tightening torque for grub screw		4	N·m
Recommended diameter for attachment bolts, mm	G	10	mm
Recommended diameter for attachment bolts, inch	G	0.375	in

Included products

Housing	SY 505 M
Bearing	YAR 205-2F

Associated products

End cover	ECY 205
-----------	-------------------------