

# SY 25 FM

Material

Cast iron

## Dimensions

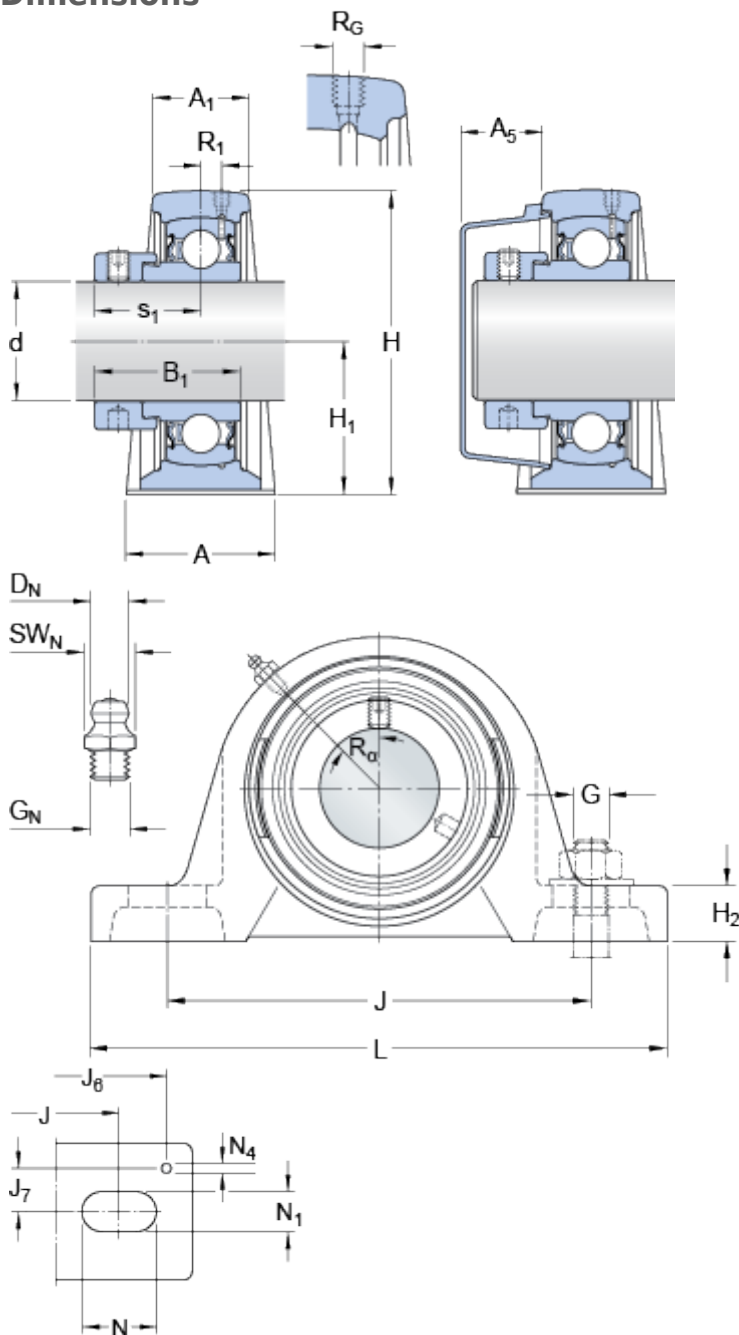

d	25	mm
A	36	mm
A <sub>1</sub>	22	mm
A <sub>5</sub>	18	mm
B <sub>1</sub>	31	mm
H	70	mm
H <sub>1</sub>	36.5	mm
H <sub>2</sub>	16	mm
J	102	mm
J	max. 110	mm
J	min. 94	mm
L	130	mm
N	19.5	mm
N <sub>1</sub>	11.5	mm
s <sub>1</sub>	23.5	mm

### Threaded hole

R<sub>G</sub> 1/4-28 UNF

R<sub>1</sub> 2 mm

R<sub>α</sub> 45 °

### Grease fitting

D<sub>N</sub> 6.5 mm

SW<sub>N</sub> 7 mm

G<sub>N</sub> 1/4-28 SAE-LT

### Dowel pins

J<sub>6</sub> 120 mm

J<sub>7</sub> 13 mm

N<sub>4</sub> 4 mm

## Calculation data

Basic dynamic load rating

C 14 kN

Basic static load rating

C 7.8 kN

Fatigue load limit

P<sub>u</sub> 0.335 kN

Limiting speed

7000 r/min

(with shaft tolerance h6)

## Mass

---

Mass bearing unit	0.71	kg
-------------------	------	----

## Mounting information

---

Hexagonal key size for grub screw	N	3	mm
Recommended tightening torque for grub screw		4	N·m
Recommended diameter for attachment bolts, mm	G	10	mm
Recommended diameter for attachment bolts, inch	G	0.375	in

## Included products

---

Housing	<a href="#">SY 505 M</a>
Bearing	<a href="#">YET 205</a>

## Associated products

---

End cover	<a href="#">ECY 205</a>
-----------	-------------------------