

# SY 20 TF

Material

Cast iron

## Dimensions

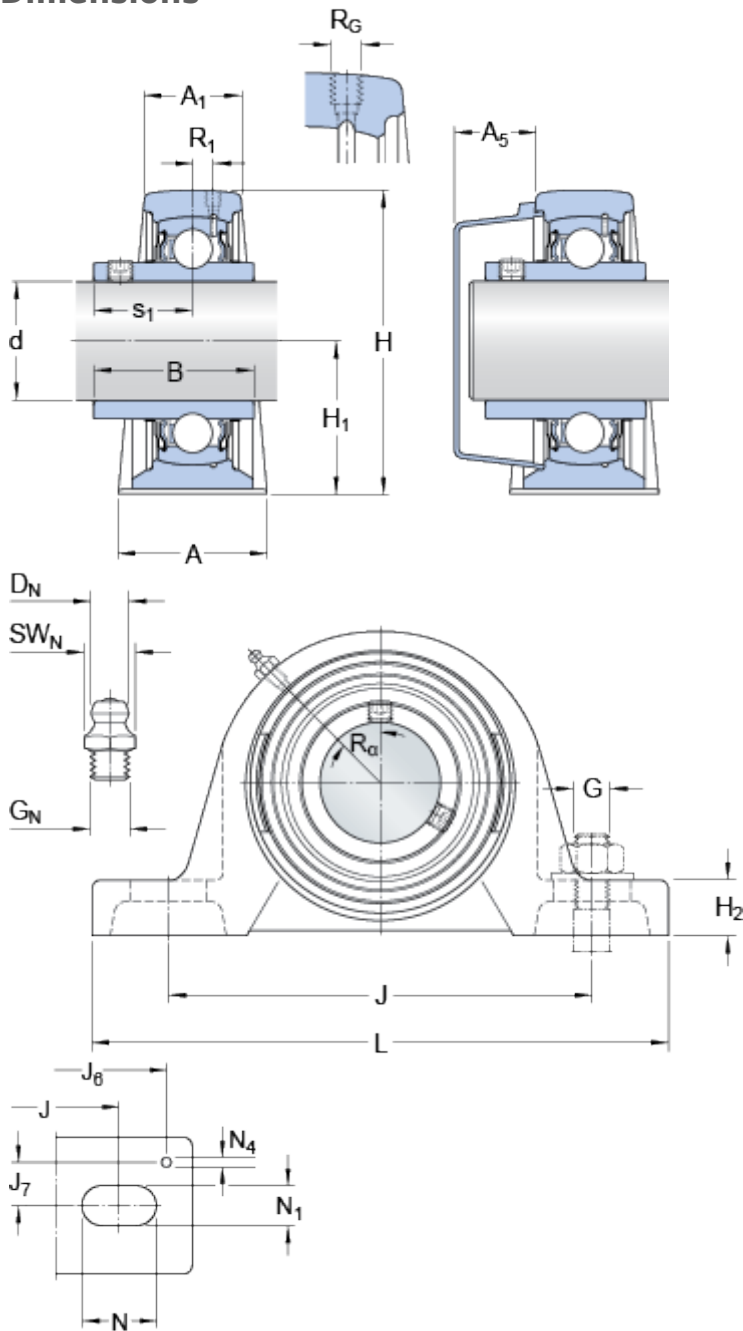

|                |          |    |
|----------------|----------|----|
| d              | 20       | mm |
| A              | 32       | mm |
| A <sub>1</sub> | 21       | mm |
| A <sub>5</sub> | 18.5     | mm |
| B              | 31       | mm |
| H              | 64.5     | mm |
| H <sub>1</sub> | 33.3     | mm |
| H <sub>2</sub> | 14       | mm |
| J              | 97       | mm |
| J              | max. 106 | mm |
| J              | min. 88  | mm |
| L              | 127      | mm |
| N              | 20.5     | mm |
| N <sub>1</sub> | 11.5     | mm |
| s <sub>1</sub> | 18.3     | mm |

### Threaded hole

|                |            |
|----------------|------------|
| R <sub>G</sub> | 1/4-28 UNF |
| R <sub>1</sub> | 2 mm       |
| R <sub>α</sub> | 45 °       |

### Grease fitting

|                 |               |    |
|-----------------|---------------|----|
| D <sub>N</sub>  | 6.5           | mm |
| SW <sub>N</sub> | 7             | mm |
| G <sub>N</sub>  | 1/4-28 SAE-LT |    |

### Dowel pins

|                |      |    |
|----------------|------|----|
| J <sub>6</sub> | 118  | mm |
| J <sub>7</sub> | 11.5 | mm |
| N <sub>4</sub> | 2    | mm |

## Calculation data

|                           |                |      |       |
|---------------------------|----------------|------|-------|
| Basic dynamic load rating | C              | 12.7 | kN    |
| Basic static load rating  | C              | 6.55 | kN    |
| Fatigue load limit        | P <sub>u</sub> | 0.28 | kN    |
| Limiting speed            |                | 8500 | r/min |

(with shaft tolerance h6)

## Mass

---

|                   |      |    |
|-------------------|------|----|
| Mass bearing unit | 0.55 | kg |
|-------------------|------|----|

## Mounting information

---

|   |   |       |     |
|---|---|-------|-----|
| Hexagonal key size for grub screw               | N | 3     | mm  |
| Recommended tightening torque for grub screw    |   | 4     | N·m |
| Recommended diameter for attachment bolts, mm   | G | 10    | mm  |
| Recommended diameter for attachment bolts, inch | G | 0.375 | in  |

## Included products

---

|         |                            |
|---------|----------------------------|
| Housing | <a href="#">SY 504 M</a>   |
| Bearing | <a href="#">YAR 204-2F</a> |

## Associated products

---

|           |                         |
|-----------|-------------------------|
| End cover | <a href="#">ECY 204</a> |
|-----------|-------------------------|