

SY 20 FM

Material

Cast iron

Dimensions

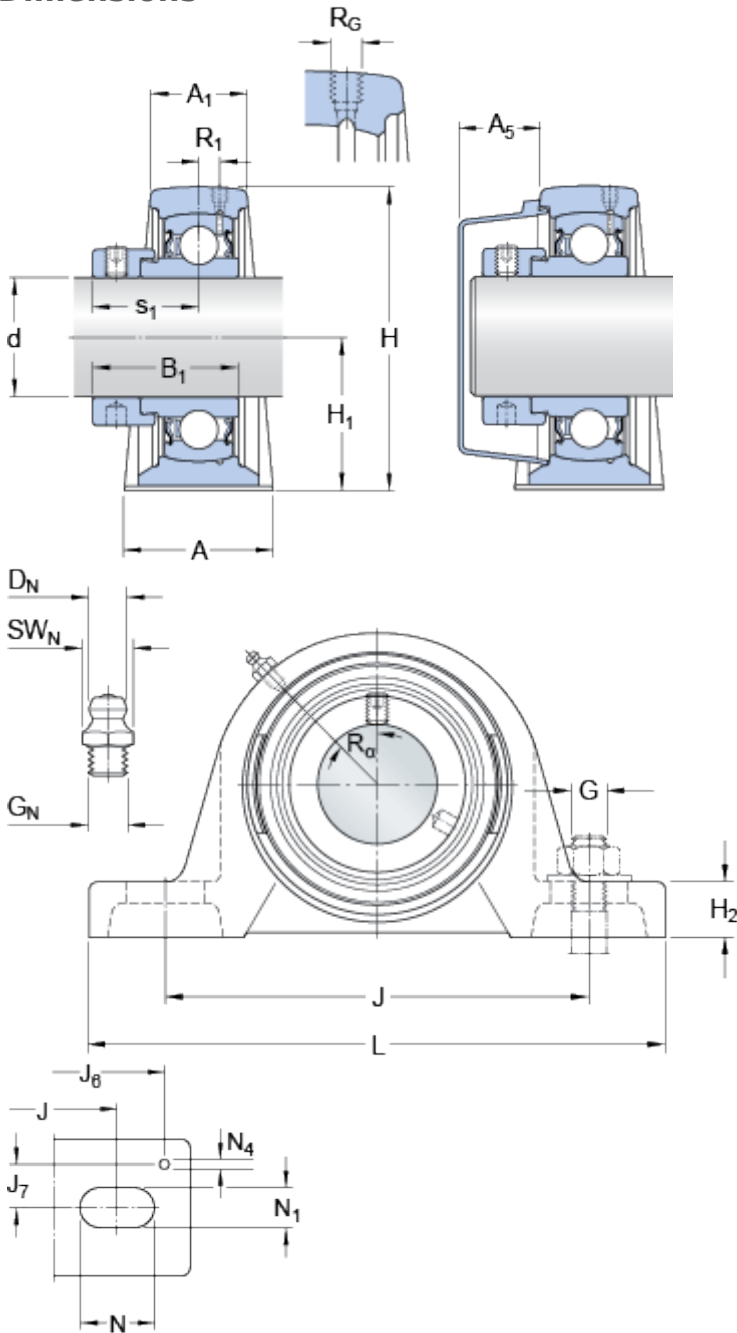

d	20	mm
A	32	mm
A ₁	21	mm
A ₅	18.5	mm
B ₁	31	mm
H	64.5	mm
H ₁	33.3	mm
H ₂	14	mm
J	97	mm
J	max. 106	mm
J	min. 88	mm
L	127	mm
N	20.5	mm
N ₁	11.5	mm
s ₁	24	mm

Threaded hole

R_G 1/4-28 UNF

R₁ 2 mm

R_α 45 °

Grease fitting

D_N 6.5 mm

SW_N 7 mm

G_N 1/4-28 SAE-LT

Dowel pins

J₆ 118 mm

J₇ 11.5 mm

N₄ 2 mm

Calculation data

Basic dynamic load rating

C 12.7 kN

Basic static load rating

C 6.55 kN

Fatigue load limit

P_u 0.28 kN

Limiting speed

8500 r/min

(with shaft tolerance h6)

Mass

Mass bearing unit	0.59	kg
-------------------	------	----

Mounting information

Hexagonal key size for grub screw	N	3	mm
Recommended tightening torque for grub screw		4	N·m
Recommended diameter for attachment bolts, mm	G	10	mm
Recommended diameter for attachment bolts, inch	G	0.375	in

Included products

Housing	SY 504 M
Bearing	YET 204

Associated products

End cover	ECY 204
-----------	-------------------------