

SY 15 TF

Material

Cast iron

Dimensions

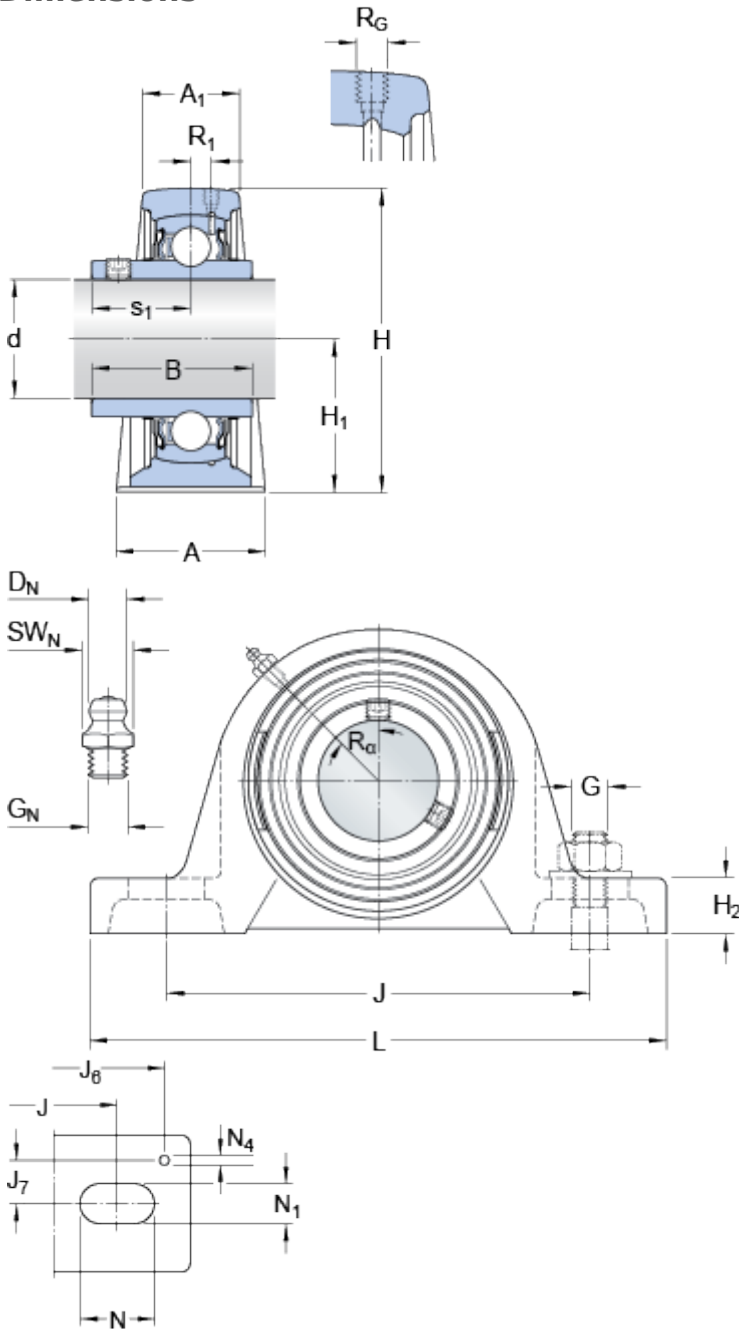

d	15	mm
A	32	mm
A_1	18	mm
B	27.4	mm
H	57	mm
H_1	30.2	mm
H_2	14	mm
J	97	mm
J	max. 106	mm
J	min. 88	mm
L	127	mm
N	20.5	mm
N_1	11.5	mm
s_1	15.9	mm

Threaded hole

R_G	1/4-28 UNF
R_1	1 mm
R_α	45 °

Grease fitting

D_N	6.5	mm
SW_N	7	mm
G_N	1/4-28 SAE-LT	

Dowel pins

J_6	118	mm
J_7	11.5	mm
N_4	2	mm

Calculation data

Basic dynamic load rating	C	9.56	kN
Basic static load rating	C	4.75	kN
Fatigue load limit	P_u	0.2	kN
Limiting speed		9500	r/min

(with shaft tolerance h6)

Mass

Mass bearing unit	0.46	kg
-------------------	------	----

Mounting information

Hexagonal key size for grub screw	N	3	mm
Recommended tightening torque for grub screw		4	N·m
Recommended diameter for attachment bolts, mm	G	10	mm
Recommended diameter for attachment bolts, inch	G	0.375	in

Included products

Housing	SY 503 M
Bearing	YAR 203/15-2F