

SYWK 35 YTH

Material

Composite for food and beverage

Dimensions

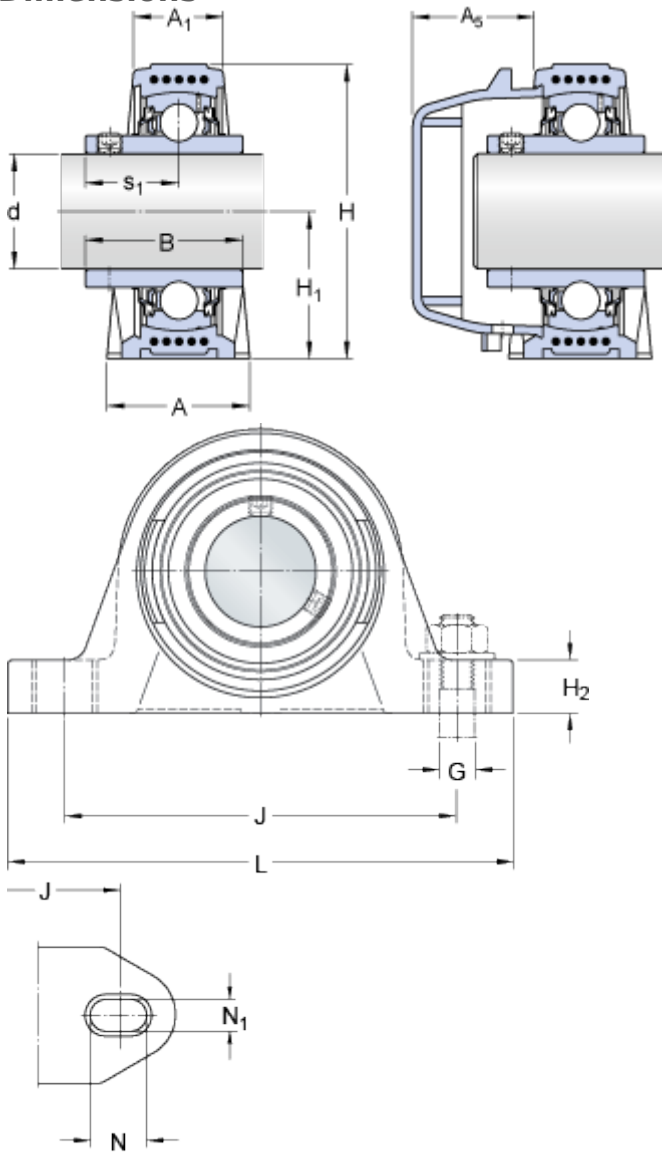

d	35	mm
A	45	mm
A ₁	27	mm
A ₅	32.5	mm
B	42.9	mm
H	93	mm
H ₁	47.6	mm
H ₂	19	mm
J	126	mm
J max.	133	mm
J min.	119	mm
L	164	mm
N	21.5	mm
N ₁	14.5	mm
s ₁	25.4	mm

Calculation data

Basic dynamic load rating	C	21.6	kN
Basic static load rating	C	15.3	kN
Fatigue load limit	P _u	0.655	kN
Limiting speed		3200	r/min
(with shaft tolerance h6)			

Mass

Mass bearing unit	0.71	kg
-------------------	------	----

Mounting information

Hexagonal key size for grub screw	N	3	mm
Recommended tightening torque for grub screw		4	N·m
Recommended diameter for attachment bolts, mm	G	12	mm

Recommended diameter for attachment bolts, inch

G 0.5 in

Included products

Housing

[SYWK 507 Y](#)

Bearing

[YAR 207-2RF/HV](#)

Associated products

End cover

[ECW 207](#)