

SYNT 45 F

Dimensions

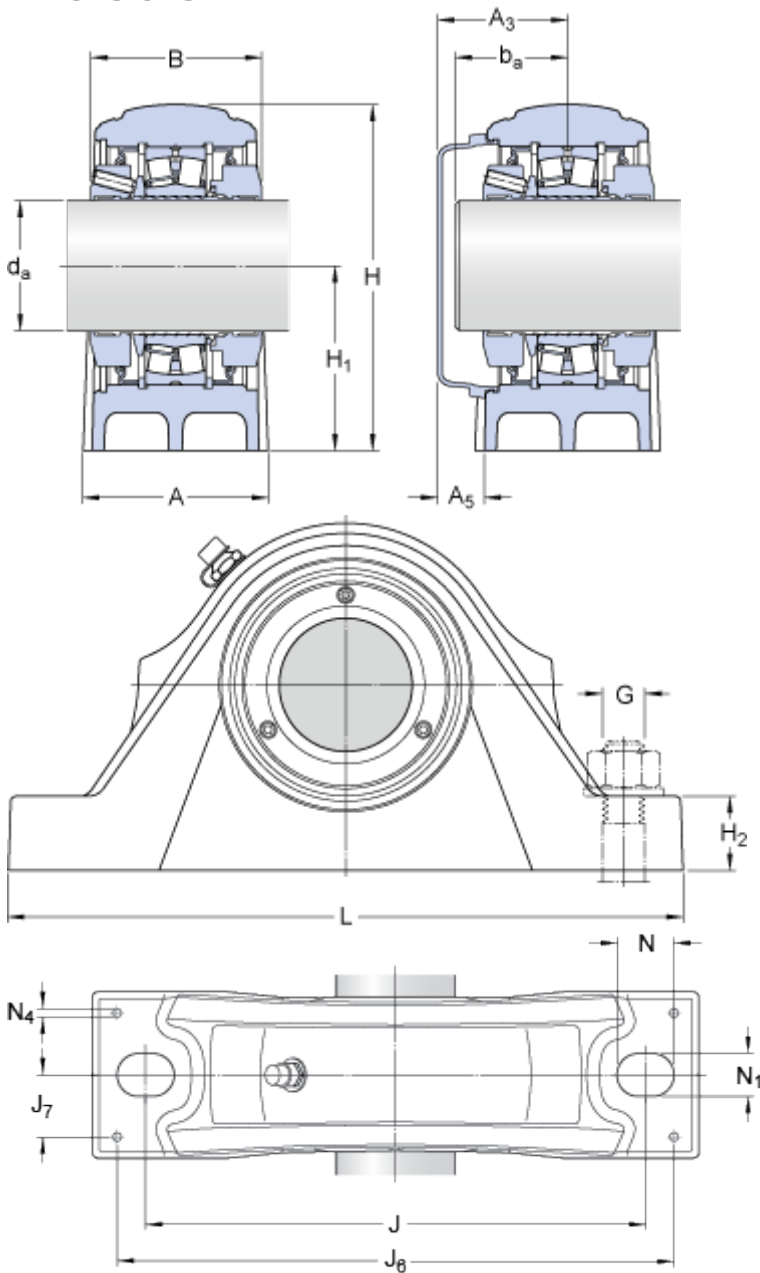

d _a	45	mm
A	60	mm
B	65	mm
H	118	mm
H ₁	60	mm
H ₂	25	mm
J	170	mm
L	205	mm
N	20	mm
N ₁	15	mm

Shaft end

A ₃	52	mm
A ₅	23	mm
b _a	min. 34	mm
b _a	max. 43	mm

Dowel pins

J ₆	185	mm
J ₇	21	mm
N ₄	max. 6	mm

Calculation data

Basic dynamic load rating	C	102	kN
Basic static load rating	C	98	kN
Fatigue load limit	P _u	10.8	kN
Limiting speed		3500	r/min
Calculation factor	e	0.26	
Calculation factor	Y ₁	2.6	
Calculation factor	Y ₂	3.9	
Bearing mean diameter	d _m	65	mm

Basic bearing designation

[22209 E](#)

Load carrying ability

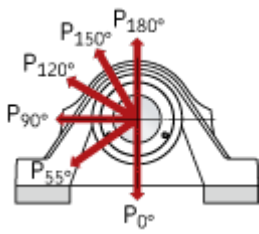

Breaking loads

P_{0°	170	kN
P_{55°	280	kN
P_{90°	170	kN
P_{120°	110	kN
P_{150°	100	kN
P_{180°	115	kN

Axial holding power

P_a	15	kN
-------	----	----

Mass

Mass bearing unit	4	kg
-------------------	---	----

Mounting information

Attachment bolt diameter	G	12	mm
Tightening torque for attachment bolts		80	N·m
Grub screws		3 x M 6	
Tightening torque for grub screws		8	N·m
Grease quantity for relubrication		4	g

Appropriate products

End cover	ECY 209
-----------	-------------------------