

SYNT 35 F

Dimensions

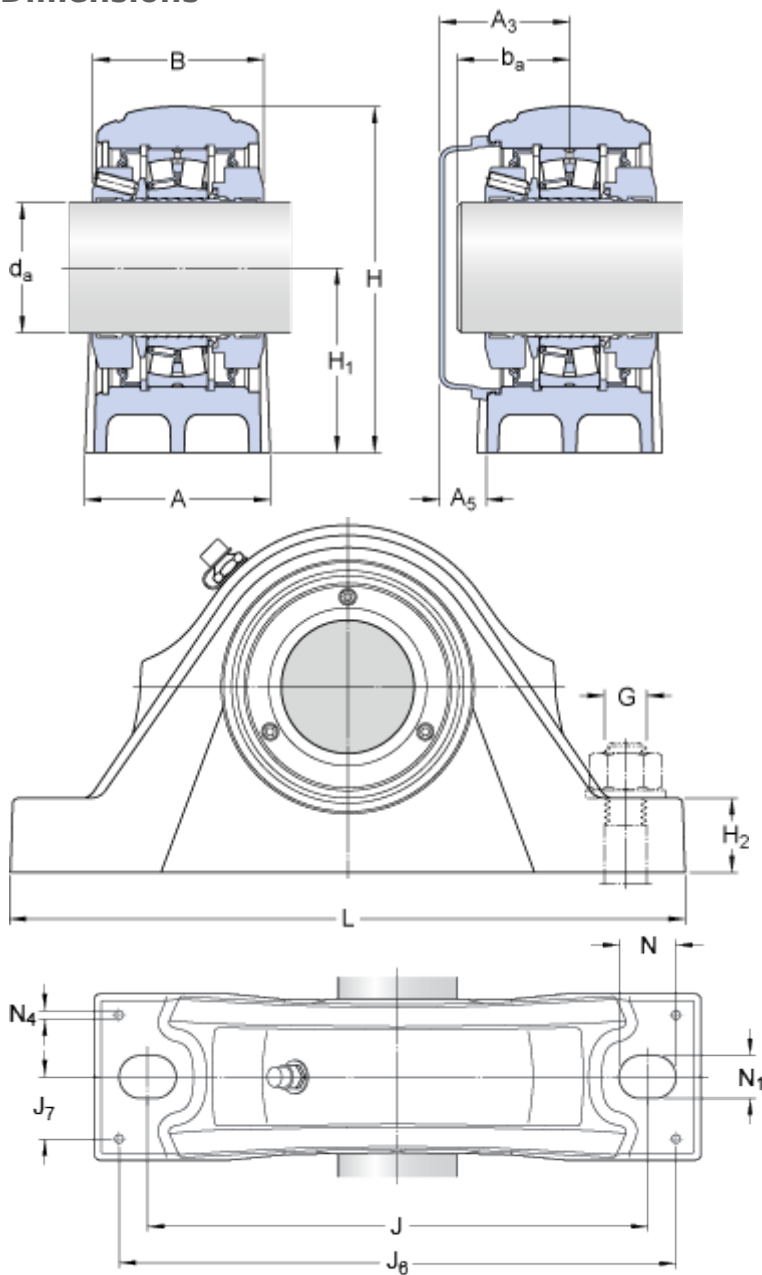

d_a	35	mm
A	60	mm
B	65	mm
H	111	mm
H_1	60	mm
H_2	25	mm
J	170	mm
L	205	mm
N	20	mm
N_1	15	mm

Shaft end

A_3	50	mm
A_5	22	mm
b_a	min. 34	mm
b_a	max. 43	mm

Dowel pins

J_6	185	mm
J_7	21	mm
N_4	max. 6	mm

Calculation data

Basic dynamic load rating	C	86.5	kN
Basic static load rating	C	85	kN
Fatigue load limit	P_u	9.3	kN
Limiting speed		4100	r/min
Calculation factor	e	0.31	
Calculation factor	Y_1	2.2	
Calculation factor	Y_2	3.3	
Bearing mean diameter	d_m	53.5	mm
Basic bearing designation		22207 E	

Load carrying ability

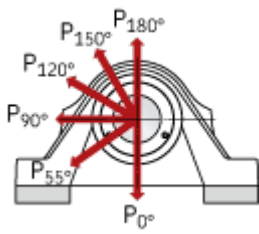

Breaking loads

P_{0°	150	kN
P_{55°	250	kN
P_{90°	150	kN
P_{120°	95	kN
P_{150°	85	kN
P_{180°	105	kN

Axial holding power

P_a	15	kN
-------	----	----

Mass

Mass bearing unit	3.8	kg
-------------------	-----	----

Mounting information

Attachment bolt diameter	G	12	mm
Tightening torque for attachment bolts		80	N·m
Grub screws		3 x M 6	
Tightening torque for grub screws		8	N·m
Grease quantity for relubrication		3	g

Appropriate products

End cover	ECY 207
-----------	-------------------------