

SYJ 100 TF

Material

Cast iron

Dimensions

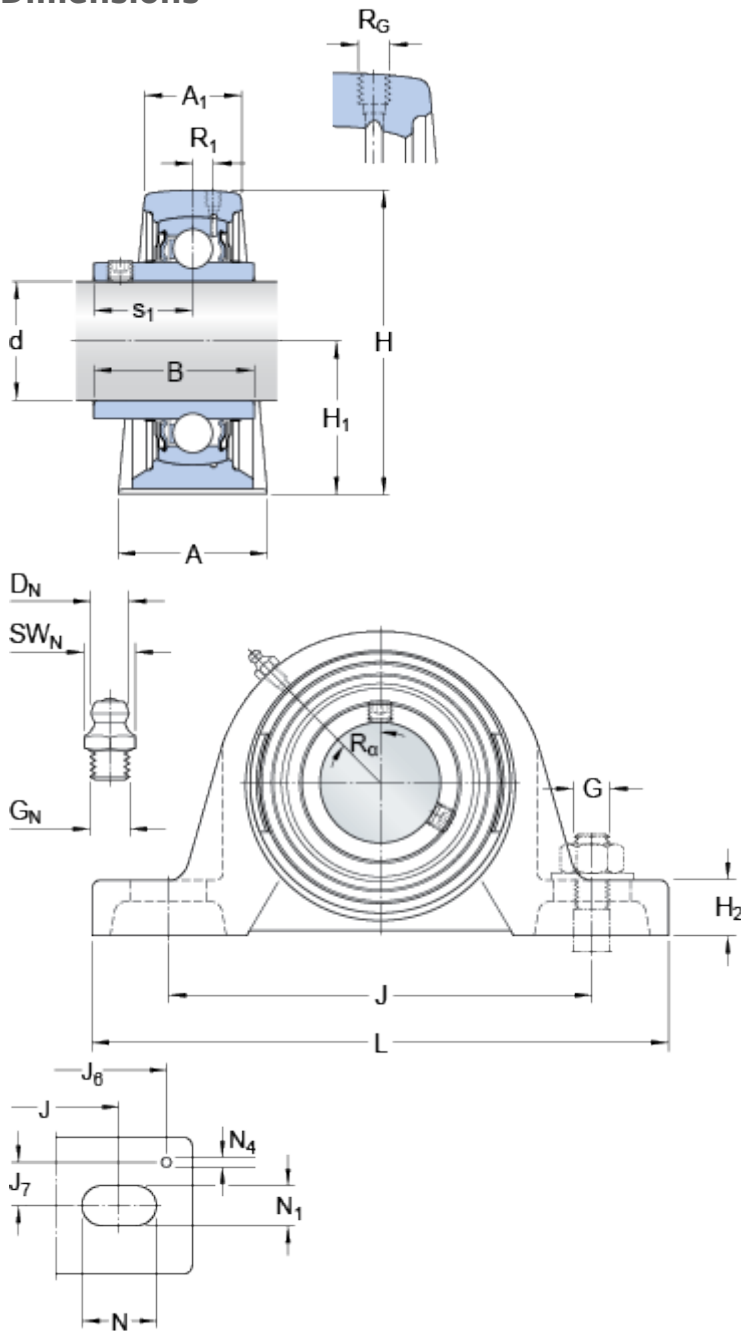

d	100	mm
A	95	mm
A_1	57	mm
B	98.4	mm
H	225.5	mm
H_1	115	mm
H_2	38	mm
J	308	mm
J	max. 330	mm
J	min. 286	mm
L	380	mm
N	48	mm
N_1	26	mm
s_1	63.4	mm

Threaded hole

R_G	1/4-28 UNF
R_1	10.5 mm
R_α	45 °

Grease fitting

D_N	6.5 mm
SW_N	7 mm
G_N	1/4-28 SAE-LT

Dowel pins

J_6	352 mm
J_7	33.5 mm
N_4	4 mm

Calculation data

Basic dynamic load rating	C	124	kN
Basic static load rating	C	93	kN
Fatigue load limit	P_u	3.35	kN
Limiting speed		1900	r/min

(with shaft tolerance h6)

Mass

Mass bearing unit	17.6	kg
-------------------	------	----

Mounting information

Hexagonal key size for grub screw	N	6	mm
Recommended tightening torque for grub screw		28.5	N·m
Recommended diameter for attachment bolts, mm	G	24	mm
Recommended diameter for attachment bolts, inch	G	0.9375	in

Included products

Housing	SYJ 520
Bearing	YAR 220-2F