

SYF 510

Dimensions

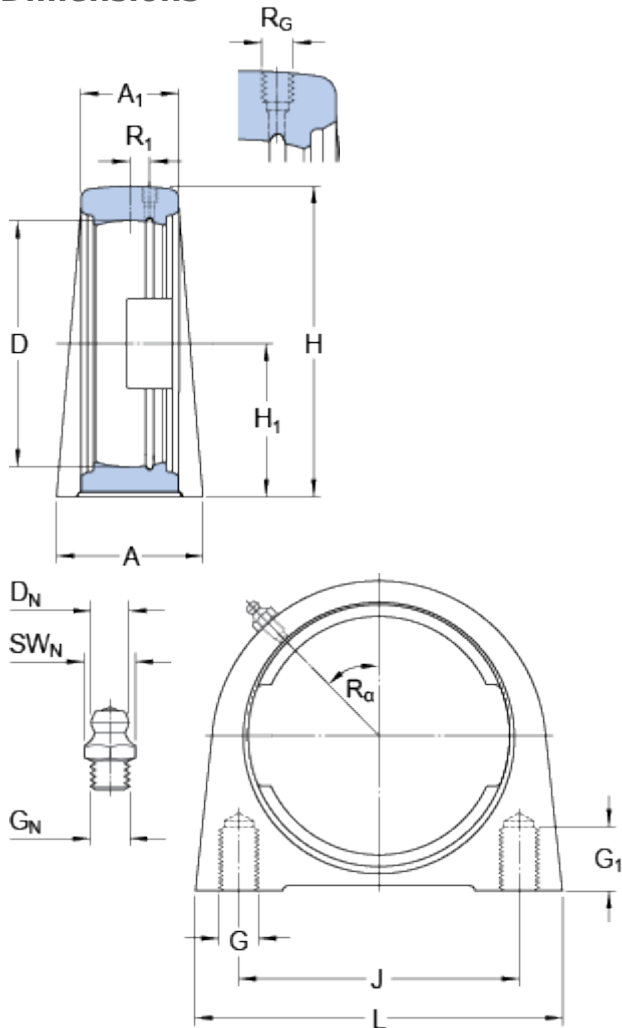

D	90	mm
H_1	57.2	mm
A	54	mm
A_1	34	mm
H	114	mm
J	101.6	mm
L	135	mm

Threaded hole

R_G	1/4-28 UNF
R_1	4 mm
R_a	45 °

Grease fitting

D_N	6.5	mm
SW_N	7	mm
G_N	1/4-28 SAE-LT	

Mass

Mass housing	1.65	kg
--------------	------	----

Mounting information

Housing thread for attachment bolts	G	M16
Thread length	G_1	25.5 mm