

# SYF 50 TF

Housing material

Cast iron

## Dimensions

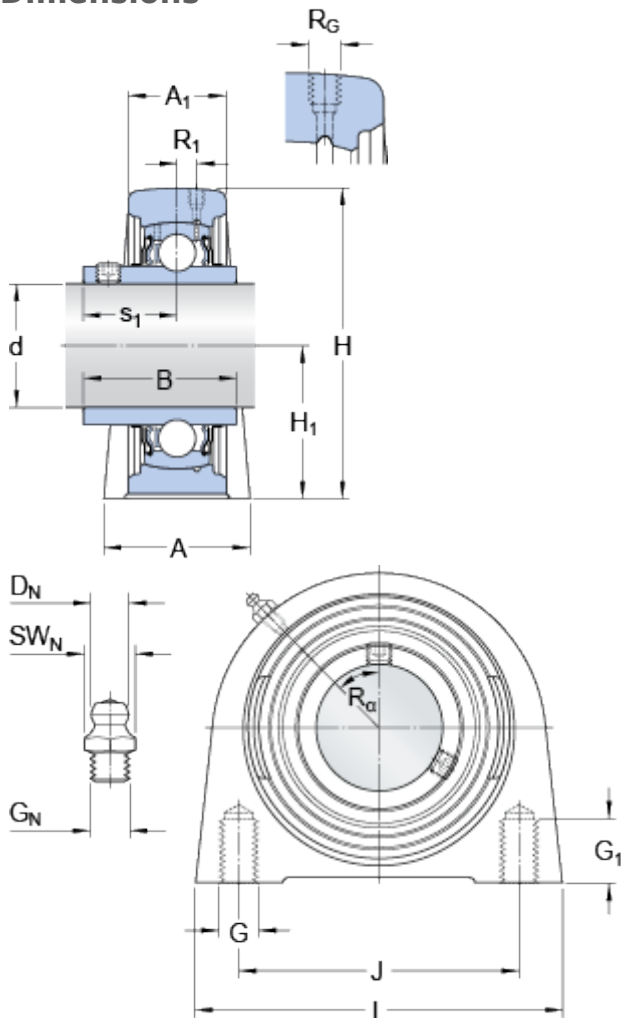

d	50	mm
A	54	mm
A <sub>1</sub>	34	mm
B	51.6	mm
H	114	mm
H <sub>1</sub>	57.2	mm
J	101.6	mm
L	135	mm
s <sub>1</sub>	32.6	mm

## Threaded hole

R <sub>G</sub>	1/4-28 UNF
R <sub>1</sub>	4 mm
R <sub>α</sub>	45 °

## Grease fitting

D <sub>N</sub>	6.5	mm
SW <sub>N</sub>	7	mm
G <sub>N</sub>	1/4-28 SAE-LT	

## Calculation data

Basic dynamic load rating	C	35.1	kN
Basic static load rating	C	23.2	kN
Fatigue load limit	P <sub>u</sub>	0.98	kN
Limiting speed		4000	r/min

(with shaft tolerance h6)

## Mass

Mass bearing unit	2.35	kg
-------------------	------	----

## Mounting information

Housing thread for attachment bolts	G	M16
Thread length	G <sub>1</sub>	25.5 mm
Thread grub screw	G <sub>2</sub>	M10x1
Hexagonal key size for grub screw	N	5 mm
Recommended tightening torque for grub screw		16.5 N·m

## Included products

Housing  
Bearing

---

SYF 510  
YAR 210-2F