

# SYFWK 25 LTHR

Housing material

Composite for food and beverage

## Dimensions

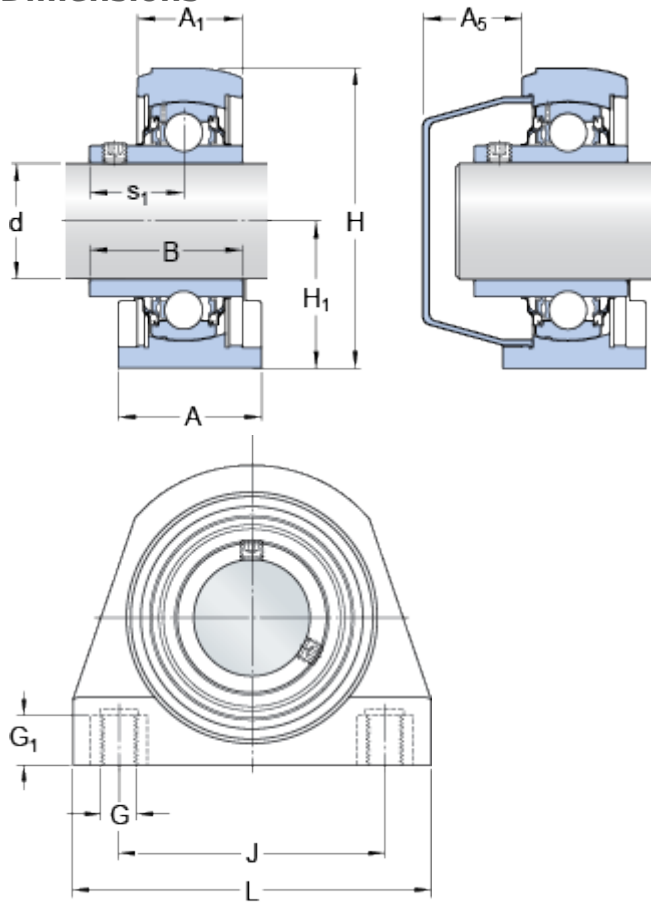

d	25	mm
A	40	mm
A <sub>1</sub>	25.5	mm
A <sub>5</sub>	22	mm
B	34.1	mm
H	73.5	mm
H <sub>1</sub>	36.5	mm
J	50.8	mm
L	76	mm
s <sub>1</sub>	19.8	mm

## Calculation data

Basic dynamic load rating	C	11.9	kN
Basic static load rating	C	7.8	kN
Fatigue load limit	P <sub>u</sub>	0.335	kN
Limiting speed		4300	r/min

(with shaft tolerance h6)

## Mass

Mass bearing unit	0.33	kg
-------------------	------	----

## Mounting information

Thread size attachment end	G	M10
Thread length	G <sub>1</sub>	12 mm
Thread grub screw	G <sub>2</sub>	M6x0.75
Hexagonal key size for grub screw	N	3 mm
Recommended tightening torque for grub screw		4 N·m

## Included products

Housing	<a href="#">SYFWK 505 L</a>
Bearing	<a href="#">YAR 205-2RFGR/HV</a>

