

SI 12 C

Dimensions

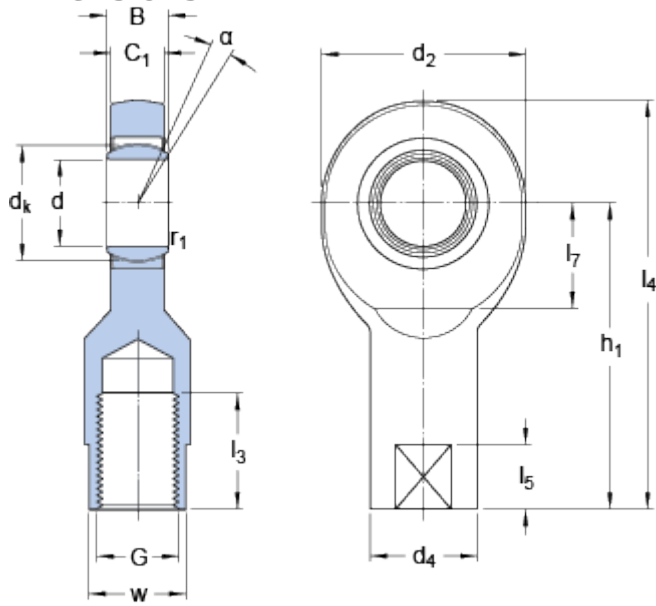

d		12	mm
d ₂	max.	35	mm
B		10	mm
G	6H	M 12	
C ₁	max.	8.5	mm
h ₁		50	mm
α		10	°
d _k		18	mm
d ₄	≈	19	mm
l ₃	min.	18	mm
l ₄	max.	69	mm
l ₅	≈	12	mm
l ₇	min.	17	mm
w	h14	17	mm
r ₁	min.	0.3	mm

Calculation data

Basic dynamic load rating	C	11.4	kN
Basic static load rating	C	25.5	kN
Specific dynamic load factor	K	100	N/mm ²
Material constant	K _M	1400	

Mass

Mass rod end		0.11	kg
--------------	--	------	----