

PWKR 35.2RS

Dimensions

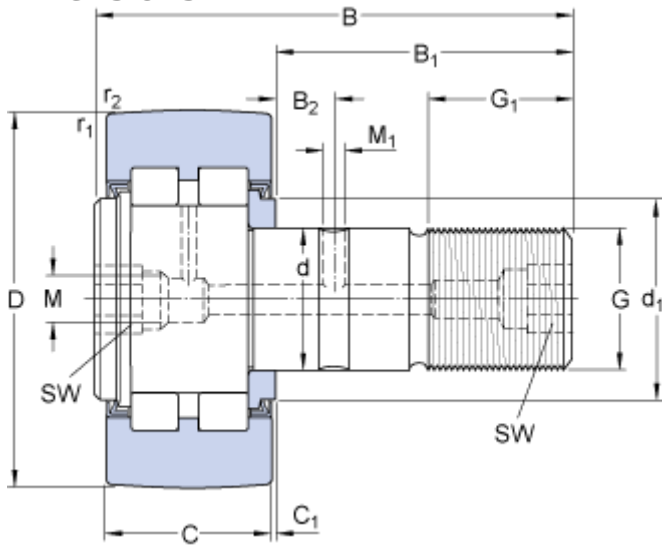

D	35	mm
d	16	mm
B	52	mm
C	18	mm
B ₁	32.5	mm
B ₂	7.8	mm
C ₁	0.8	mm
d ₁	20	mm
G	M 16x1.5	
G ₁	17	mm
M	6	mm
M ₁	3	mm
SW	8	mm
r _{1,2}	min. 0.6	mm

Calculation data

Basic dynamic load rating	C	11.9	kN
Basic static load rating	C	11.4	kN
Fatigue load limit	P _u	1.2	kN
Maximum dynamic radial loads	F _r	max. 8.65	kN
Maximum static radial loads	F _{0r}	max. 12.5	kN
Limiting speed		5000	r/min

Mass

Mass cam follower	0.16	kg
-------------------	------	----

Mounting information

Recommended tightening torque	58	N·m
-------------------------------	----	-----

Included products

Grease fitting	NIP A2x7.5
Hexagonal nut	M 16x1.5

Associated products

Lubrication adapter	AP 8
---------------------	------

