

NU 211 ECM

SKF Explorer

Dimensions

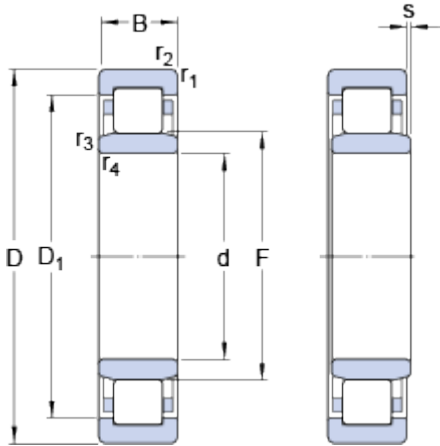

d	55	mm
D	100	mm
B	21	mm
D ₁	≈ 85.6	mm
F	66	mm
r _{1,2}	min. 1.5	mm
r _{3,4}	min. 1.1	mm
s	max. 1	mm

Abutment dimensions

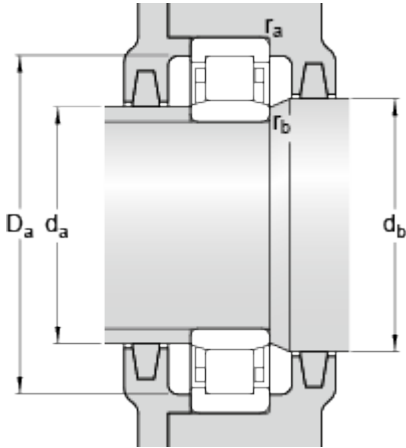

d _a	min. 62	mm
d _a	max. 64	mm
d _b	min. 68	mm
D _a	max. 91.4	mm
r _a	max. 1.5	mm
r _b	max. 1	mm

Calculation data

Basic dynamic load rating	C	96.5	kN
Basic static load rating	C	95	kN
Fatigue load limit	P _u	12.2	kN
Reference speed		7500	r/min
Limiting speed		8000	r/min
Calculation factor	k _r	0.15	
Limiting value	e	0.2	
Axial load factor	Y	0.6	

Mass

Mass bearing	0.77	kg
--------------	------	----

Associated products

Angle ring	HJ 211 EC
------------	-----------

