

NU 207 ECP

SKF Explorer

Dimensions

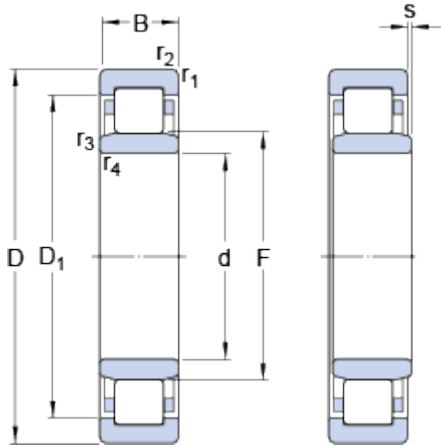

d		35	mm
D		72	mm
B		17	mm
D ₁	≈	60.2	mm
F		44	mm
r _{1,2}	min.	1.1	mm
r _{3,4}	min.	0.6	mm
s	max.	1.3	mm

Abutment dimensions

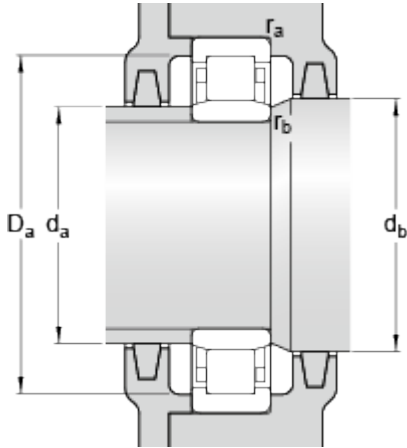

d _a	min.	39.8	mm
d _a	max.	42.2	mm
d _b	min.	46	mm
D _a	max.	65.1	mm
r _a	max.	1	mm
r _b	max.	0.6	mm

Calculation data

Basic dynamic load rating	C	56	kN
Basic static load rating	C	48	kN
Fatigue load limit	P _u	6.1	kN
Reference speed		11000	r/min
Limiting speed		12000	r/min
Calculation factor	k _r	0.15	
Limiting value	e	0.2	
Axial load factor	Y	0.6	

Mass

Mass bearing		0.29	kg
--------------	--	------	----

Associated products

Angle ring		HJ 207 EC	
------------	--	-----------	--

