

NU 202 ECP

Dimensions

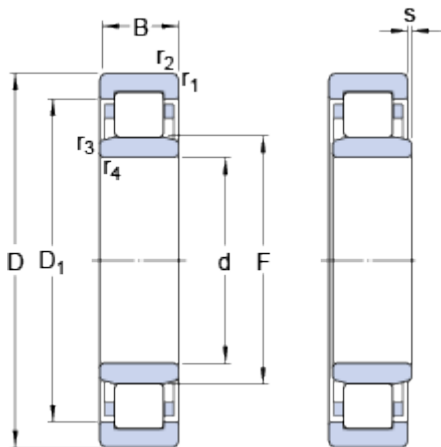

d		15	mm
D		35	mm
B		11	mm
D ₁	≈	27.7	mm
F		19.3	mm
r _{1,2}	min.	0.6	mm
r _{3,4}	min.	0.3	mm
s	max.	1	mm

Abutment dimensions

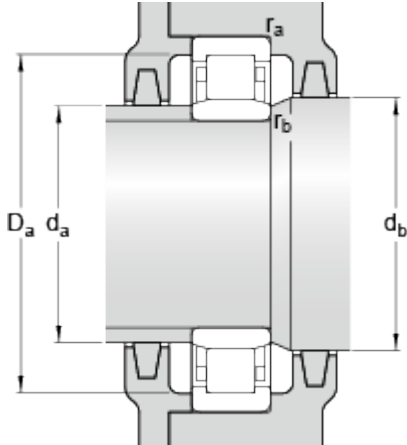

d _a	min.	17.4	mm
d _a	max.	18.4	mm
d _b	min.	21	mm
D _a	max.	31.3	mm
r _a	max.	0.6	mm
r _b	max.	0.3	mm

Calculation data

Basic dynamic load rating	C	12.5	kN
Basic static load rating	C	10.2	kN
Fatigue load limit	P _u	1.22	kN
Reference speed		22000	r/min
Limiting speed		26000	r/min
Calculation factor	k _r	0.15	
Limiting value	e	0.2	
Axial load factor	Y	0.6	

Mass

Mass bearing		0.047	kg
--------------	--	-------	----