

# NUTR 50 A

## Dimensions

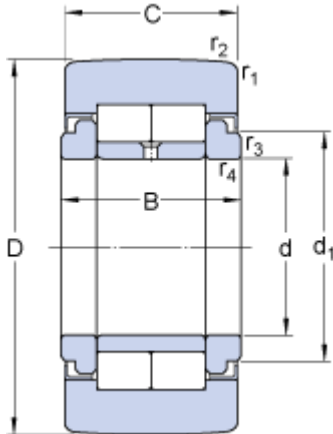

D	90	mm
d	50	mm
C	30	mm
B	32	mm
d <sub>1</sub>	59.8	mm
r <sub>1,2</sub>	min. 1.1	mm
r, r <sub>3,4</sub>	min. 0.6	mm

## Calculation data

Basic dynamic load rating	C	58.3	kN
Basic static load rating	C	78	kN
Fatigue load limit	P <sub>u</sub>	9.65	kN
Maximum dynamic radial loads	F <sub>r</sub>	max. 32.5	kN
Maximum static radial loads	F <sub>0r</sub>	max. 47.5	kN
Limiting speed		1600	r/min

## Mass

Mass support roller		0.95	kg
---------------------	--	------	----